

Solid-State Photochemistry of Guest Aliphatic Ketones inside the Channels of Host Deoxycholic and Apocholeic Acids

R. Popovitz-Biro, C. P. Tang, H. C. Chang, M. Lahav,* and L. Leiserowitz*

Contribution from the Department of Structural Chemistry, The Weizmann Institute of Science, Rehovot, Israel 76100. Received July 11, 1984

Abstract: Deoxycholic acid (DCA) forms channel inclusion complexes with acetone (host-guest molar ratio 5:3), diethyl ketone (2:1), and ethyl methyl ketone (2:1). UV irradiation of these three complexes led to stereospecific photoaddition of the guests at sites [C5, C6_{eq}, C6_{ax}], C6_{eq}, and [C6_{eq}, C5] of the host, respectively. Crystal structures of DCA-acetone and DCA-ethyl methyl ketone at temperatures of 103 K were determined and of DCA-diethyl ketone at 293 K. The host structures are isomorphous; they form hydrogen-bonded bilayers which are juxtaposed by hydrophobic contacts to form inclusion channels delineated by four walls. The occluded ketones are sandwiched between the wide walls of the channel comprising the steroid rings A and B. The regio- and stereospecificity of these reactions are explained on topochemical grounds. The 3:1 complex of DCA-methyl pentyl ketone is very similar to that of DCA-ethyl methyl ketone. Photoirradiation leads to cleavage of the ketone, yielding acetone which subsequently adds to DCA at site C5 and C6. A different channel motif was engineered in which cyclohexanone was sandwiched between rings D and the steroid side chains, leading to photoaddition to site C16 of ring D. The 1:1 complex of (APA) apocholeic acid-acetone is light stable. The X-ray structure analysis indicates a similar host bilayer structure as DCA. The acetone molecules are stacked up the channel axis, unlike in DCA-acetone, and are arranged such that the ketone C'=O' bond tends to be parallel to the nearest C-H of the steroid wall. According to this analysis the maximal distances between the ketone C'=O' group and the potentially reactive steroid C-H bond are 3.5 Å for O...H and 4.2 Å for C'...C. The angle between the planar guest ketone group and the potentially reactive C-H bond of the host steroid was found to vary over a wide range from about 50° to 90°.

1. Introduction

Recently, much effort has been directed toward increasing selectivity of chemical transformations, by organizing the potential reactants in micelles,¹ liquid crystals,² crown ethers,^{3a} cryptates,^{3b} cyclodextrins,⁴ and monolayers.⁵ During the process of organization, partial constraints are imposed upon the reactants, limiting the overall number of possible transition states which can be formed, subsequently decreasing the number of products formed.

One may also exploit the crystalline phase which generally imposes severe constraints on molecular movement and normally allows only a single conformation. Consequently, highly stereoselective and enantioselective reactions have been successfully accomplished in crystals, where the molecules are appropriately oriented for reaction.⁶ The major drawback of these crystalline systems is that they generally each comprised molecules of the same kind which were too tightly packed in the solid to better maneuver themselves to react. One way to bypass this disadvantage is to design crystalline molecular inclusion host-guest complexes, where the guests assume defined crystallographic sites and orientations but are still sufficiently loosely packed to undergo multistep stereo- or regiospecific reactions with nearest-neighbor host molecules. Furthermore, such crystalline complexes would be expected to preserve their integrity during the course of a

chemical reaction⁷ by virtue of the dominance of the host lattice. Such crystals should thus prove to be useful to study mechanisms of organic reactions. So far molecular inclusion complexes have been exploited for performing stereospecific polymerization reactions⁸ and for the resolution of enantiomers by the process of fractional crystallization.⁹ Here we shall describe reactions between host and guest, and as models we selected to investigate the functionalization of the bile acids, through activation of the included guests.

With the above ideas in mind, we have examined the solid-state photoaddition of a variety of guest aliphatic ketones (Figure 1c-g) to host molecules deoxycholic acid (DCA) and apocholeic acid (APA) (Figure 1a,b) to establish whether the crystalline matrices are appropriate models for elucidating reaction pathways.

2. Packing of Host Molecules in DCA Inclusion Complexes

According to X-ray crystal structure analyses of several DCA complexes previously reported and those we shall describe in this series, it became clear that DCA generally crystallizes in three crystal classes, orthorhombic, which is the most commonly observed,¹⁰⁻¹² tetragonal,¹³ and hexagonal.¹⁴ The photochemical

(1) Thomas, J. R. *Chem. Rev.* **1980**, *83*, 203-299. Turro, N. J.; Graetzel, M.; Braun, A. M. *Angew. Chem., Int. Ed. Engl.* **1980**, *191*, 675. Whitten, D. G. *Angew. Chem., Int. Ed. Engl.* **1978**, *82*, 937. Fendler, J. M. *Acc. Chem. Res.* **1980**, *13*, 7; *J. Phys. Chem.* **1980**, *84*, 1485.

(2) Anderson, V. C.; Craig, B. B.; Weiss, R. G. *J. Am. Chem. Soc.* **1982**, *104*, 2972. Levanon, H. *Chem. Phys. Lett.* **1982**, *90*, 465.

(3) (a) Cram, J. D.; Cram, J. M. *Acc. Chem. Res.* **1978**, *11*, 8. (b) Lehn, J. M. *Acc. Chem. Res.* **1978**, *11*, 49.

(4) Bender, M. L.; Komiyama, M. "Cyclodextrin Chemistry"; Springer-Verlag: New York, 1978. Tabushi, I. *Acc. Chem. Res.* **1982**, *15*, 66.

(5) (a) Kuhn, H.; Mobius, D. *Angew. Chem., Int. Ed. Engl.* **1971**, *10*, 620. (b) Gaines, Jr. "Insoluble Monolayers at Liquid-Gas Interface"; Interscience: New York, 1966. (c) Fendler, J. H. "Membrane Mimetic Chemistry"; Wiley-Interscience: New York, 1982.

(6) (a) Schmidt, G. M. *J. Pure Appl. Chem.* **1971**, *51*, 647. (b) Addadi, L.; Ariel, S.; Lahav, M.; Leiserowitz, L.; Popovitz-Biro, R.; Tang, C. P. *J. Chem. Soc., Spec. Period. Rep.*, **1980**, *8*, 202. (c) Curtin, D. Y.; Paul, I. C. *Chem. Rev.* **1981**, *81*, 525. (d) Gavezzotti, A.; Simonetta, M. *Chem. Rev.* **1982**, *82*, 1. (e) Scheffer, J. R. *Acc. Chem. Res.* **1980**, *13*, 283. (f) Thomas, J. M. *Pure Appl. Chem.* **1979**, *51*, 1065. (g) Hasegawa, M. *Chem. Rev.* **1983**, *85*, 507 and reference cited therein.

(7) (a) Kaiser, J.; Wegner, G.; Fischer, E. W. *Isr. J. Chem.* **1972**, *10*, 157. (b) Nakanishi, H.; Jones, W.; Thomas, J. M.; Hurshouse, H. B.; Moltevalli, M. *J. Chem. Soc., Chem. Commun.* **1980**, 611. (c) Camerman, N.; Camerman, A. *Science (Washington, D. C.)* **1968**, *160*, 1451. (d) Ohashi, Y.; Yanagi, K.; Kurihara, T.; Sasada, Y.; Ohgo, Y. *J. Am. Chem. Soc.* **1981**, *103*, 5805. (e) Kurihara, T.; Ohashi, Y.; Sasada, Y. *Acta Crystallogr., Sect. B* **1983**, *B39*, 243.

(8) (a) Chatani, Y.; Kuwata, S. *Macromolecules* **1975**, *8*, 12 and references cited therein. (b) Farina, M.; Di Silverstro, G.; Sozzani, P. *Mol. Cryst. Liq. Cryst.* **1983**, *93*, 169.

(9) (a) Tsoucaris, G.; Knossow, M.; Green, B. S.; Arad-Yellin, R. *Mol. Cryst. Liq. Cryst.* **1983**, *96*, 181. (b) Schlenk, H. *Prog. Chem. Fats Other Lipids*, **1954**, *2*, 243.

(10) Preliminary results have been published in: (a) Lahav, M.; Leiserowitz, R.; Popovitz-Biro, R.; Tang, C. P. *J. Am. Chem. Soc.* **1978**, *100*, 2542. (b) Popovitz-Biro, R.; Chang, H. C.; Tang, C. P.; Schochet, N. R.; Lahav, M.; Leiserowitz, L. *Pure Appl. Chem.* **1980**, *52*, 2693. (c) Chang, H. C.; Popovitz-Biro, R.; Lahav, M.; Leiserowitz, L. *J. Am. Chem. Soc.* **1982**, *104*, 614.

(11) (a) Craven, B. M.; DeTita, G. T. *J. Chem. Soc., Chem. Commun.* **1972**, 530. (b) DeSanctis, S. C.; Giglio, E.; Pavel, V.; Quagliata, C. *Acta Crystallogr., Sect. B* **1972**, *B28*, 3556.

(12) Friedman, N.; Lahav, M.; Leiserowitz, L.; Popovitz-Biro, R.; Tang, C. P.; Zaretskii, Z. V. *J. Chem. Soc., Commun.* **1975**, 864.

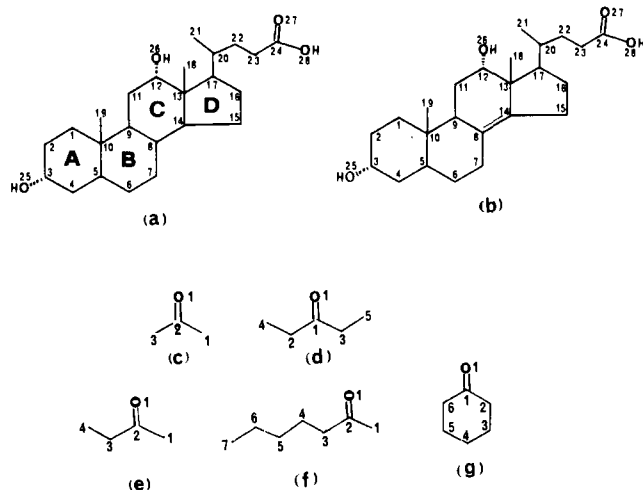

Figure 1. Atom labeling of the host and guest molecules studied by diffraction in this analysis: (a), (b) host molecules deoxycholic acid (DCA) and apocholeic acid (APA); (c)–(g) guest ketone molecules.

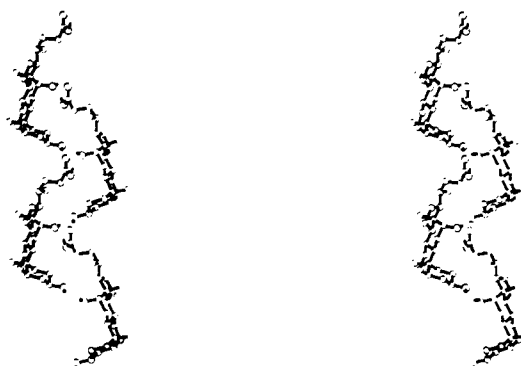

Figure 2. (001) bilayer formed by DCA molecules interlinked by O...O hydrogen bonds. Stereoscopic view along the *c* axis.

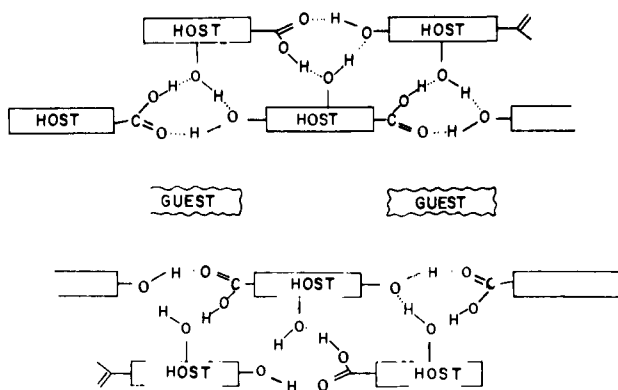

Figure 3. Schematic view of juxtaposed (001) bilayers to generate channels.

reactions were performed so far only in orthorhombic crystals, which form four types of channel wall motifs depending on the nature of the occluded guest. Common to all four motifs is the host bilayer (Figure 2). Within this bilayer, the steroid molecules are interlinked front-to-end by $>C3-O-H \cdots O=C-OH$ hydrogen bonds, along the $13.5\text{-}\text{\AA}$ *b* axis. These chains are interlinked by $O26-H \cdots O25$ and $O=C-O-H \cdots O26$ hydrogen bonds along the $7.2\text{-}\text{\AA}$ *c* axis via 2_1 axes parallel to *b* (Figure 2) to form *bc* bilayers. These bilayers contain grooves parallel to the *c* axis

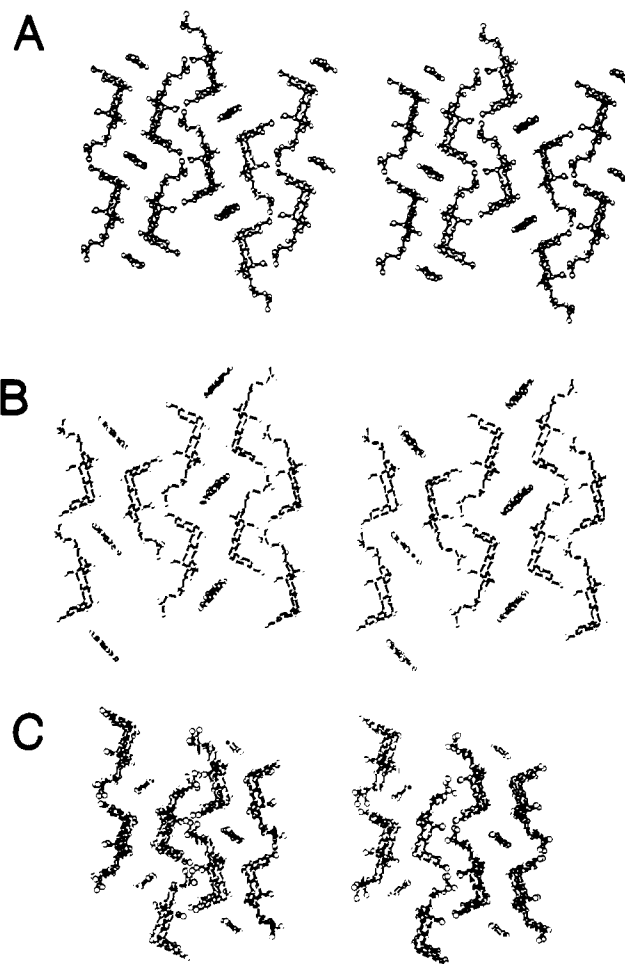

Figure 4. Stereoscopic views of the α , β , and γ motifs formed by DCA: (a) The α motif, DCA–methyl pentyl ketone; (b) β motif, DCA–phenanthrene; (c) The γ motif, DCA–cyclohexanone.

(Figure 2) and juxtapose along the *a* axis, so that the grooves combine into channels shown schematically in Figure 3. To best fit the guest molecule, the cross section of the channel may be varied, within limits, by a change in interlayer separation along *a*, by an offset along the *b* axis between neighboring bilayers and by relating the juxtaposed bilayers about the channel *c* axis by (pseudo) twofold or by twofold screw symmetry. These variations yield four channel motifs, α , β , γ , and δ . In both the α and β motifs, the adjacent bilayers are related by twofold screw symmetry, the axes of which pass along the channel centers, to yield a $P2_12_12_1$ space group. These α and β motifs exhibit different channel cross sections, induced by a difference in length of the *a* axis and in particular by a difference in offset along the *b* axis of the juxtaposed bilayers as shown for DCA–methyl pentyl ketone and DCA–phenanthrene^{11b} in Figure 4A and B, respectively. Small flat guest molecules usually induce the α motif; they occupy the channel with their best planes sandwiched by the channel walls comprising steroid rings A and B. The channel of the β motif accommodates bulkier guest molecules than the α motif. The best planes of the guest molecules in the β motif are wedged between the steroid channel walls comprised of rings D and their side chains, in contrast to the α motif.

The bilayer structure in the γ motif is similar to the β motif in terms of the direction of offset along *b* between juxtaposed bilayers. The former differs insofar that nearest-neighbor steroid molecules along the *c* axis are related by pseudotranslation, resulting in a $2 \times 7.2\text{ \AA}$ axial length with two host molecules per asymmetric unit; moreover, the juxtaposed bilayers are related by pseudotwofold symmetry about each channel axis although the true channel symmetry is a twofold screw axis as shown in Figure 4C for DCA–cyclohexanone. Thus, the true space group is $P2_12_12_1$, but the host arrangement is pseudo- $P2_12_12_1$. Finally there

(13) (a) Tang, C. P.; Popovitz-Biro, R.; Lahav, M.; Leiserowitz, L. *Isr. J. Chem.* **1979**, *19*, 285. (b) Coiro, V. M.; D'Andrea, A.; Giglio, E. *Acta Crystallogr., Sect. B* **1979**, *B35*, 2941.

(14) DeSanctis, S. C.; Giglio, E.; Petri, F.; Quagliata, C. *Acta Crystallogr., Sect. B* **1979**, *B35*, 226.

Scheme I

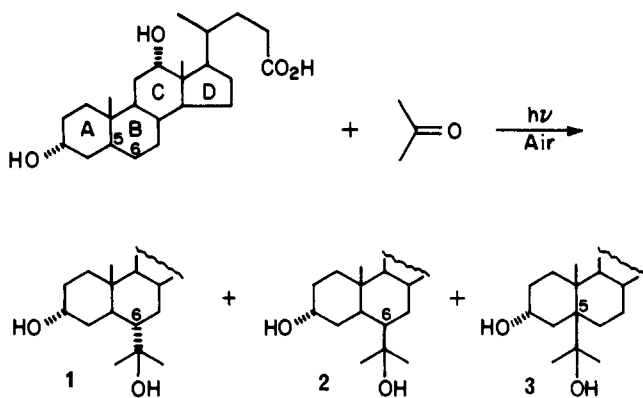

Scheme II

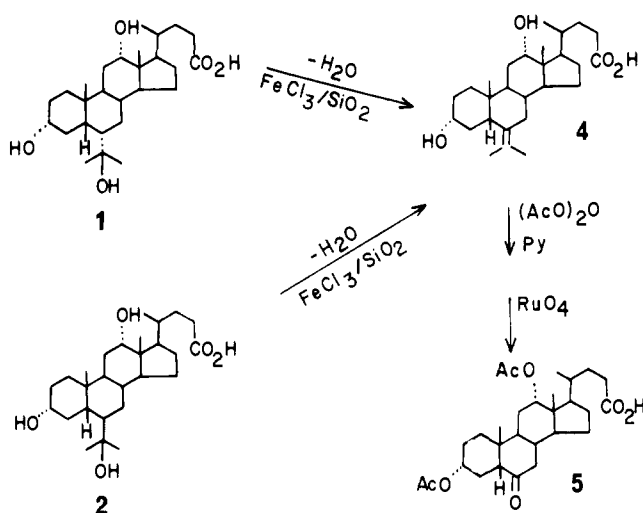

Scheme III

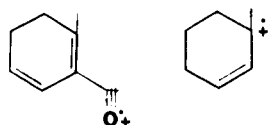

is the δ motif¹⁵ in space group $P2_12_12_1$; namely, the structure contains a twofold axis along the channel of length 7.2 Å.

The relative stabilities of the α - and β -DCA host structures have been examined in terms of van der Waals energy calculations by DeSanctis and Giglio^{16a} and independently by Tang.^{16b} The energy results indicate that the α -form host structure is the more stable of the two.

3. Photochemical and Crystallographic Results

3.1. DCA-Acetone. The 5:3 DCA-acetone complex (mp 170–175 °C) was prepared by crystallization of DCA from acetone solution. Irradiation of the complex in air during 10 days (see Experimental Section) led to the formation of three products, **1** (20%), **2** (4%), **3** (2%), resulting from photoaddition of the occluded acetone to host DCA as shown in Scheme I. Of the starting material, 70% could be recovered.

Structure Assignment of Photoproducts. The products from UV irradiation of DCA-acetone (Scheme I) were assigned according to mass spectrometric data, ¹³C NMR spectra together with partially relaxed T1 measurements, and by chemical mod-

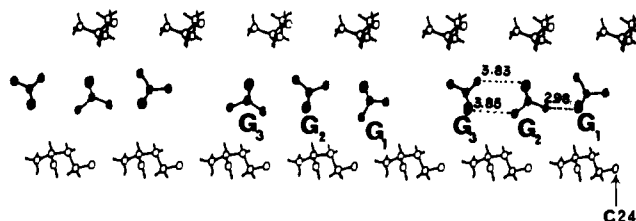

Figure 5. DCA-acetone. The packing arrangement of acetone molecules G1, G2, and G3 in the channel. The adjacent triplets (G1G2G3) along the channel are interrelated by twofold screw symmetry. Part of the steroid side chain forming the channel walls is shown.

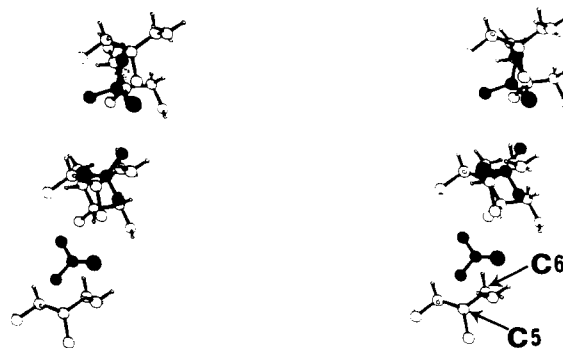

Figure 6. DCA-acetone. Stereoscopic view of the host-guest packing leading to photoreaction. The steroid fragment C3-C4-C5(C10)-C6-C7, forming part of the channel walls, is shown.

ifications to known compounds. Compounds **1** and **2** lose water under the mass spectrometric conditions and have identical mass spectra. The largest mass observed for their methyl esters was m/e 446 ($M^+ - H_2O$); the molecular peak was very weak but was proved by metastable scanning to be m/e 464 (M^+), which indicates the addition of acetone to the host.

Compounds **1** and **2** were dehydrated by $FeCl_3$ on a SiO_2 support¹⁷ in vacuum. Both gave the same compound **4**, indicating that they are two stereoisomers generated by addition of acetone to the same carbon of the steroid. Oxidation of the diacetylated methyl ester of **4** with RuO_4 gave the 6-ketodeoxycholic acid homologue **5** (Scheme II). The structure of compound **5** could be demonstrated by characteristic degradation observed in its high-resolution mass spectrum. In addition to the molecular peak m/e 504 and peaks indicating loss of acetic acid (m/e 444 and 384), two most characteristic fragments m/e 121 and 95 (Scheme III) were obtained, indicating the formation of the ketone at atom C6 of the steroid.¹²

The ¹³C NMR spectra and partially relaxed T1 measurements of compounds **1** and **2** show that C6 changes its multiplicity in both compounds from secondary to tertiary and the signals shift from 27.4 ppm in DCA to 32.7 and 34.0 ppm for **1** and **2**, respectively. From models it can be seen that in the C6 equatorial isomer, there is a strong interaction of the isopropyl group with C4 and a weak one with C7, whereas in the axial isomer these interactions are reversed. This is nicely reflected in the ¹³C NMR spectra; in compound **1** there is a large shift of C4 (+7.5 ppm, synaxial effect) and a weak effect on C7 (−0.4 ppm), while in compound **2** C7 is shifted by +2.1 ppm.

The structure of **3** was assigned as an addition product of acetone to atom C5 of DCA, since **3** has two new quaternary carbons C5 at 48.5 ppm (+4.9 ppm) and $(CH_3)_2COH$ at 80.5 ppm; in addition there is a strong gauche effect of −3.8 ppm on C19 and an effect of +5.8 ppm on C10, relative to DCA.¹⁸

Crystal Structure of 5:3 DCA-Acetone. The X-ray crystal structure at 293 K was originally analyzed by assuming a 2:1 host-guest ratio and one acetone molecule per asymmetric unit.^{10c} The refined thermal motion of the guest was, however, suspected,

(15) Jones, G. T.; Schwarzbaum, S.; Lessinger, L.; Low, B. W. *Acta Crystallogr., Sect. B* **1982**, *B38*, 1207.

(16) (a) DeSanctis, S. C.; Giglio, E. *Acta Crystallogr., Sect. B* **1979**, *B35*, 2650. (b) Tang, C. P. Ph.D. Thesis, Feinberg Graduate School, Rehovot, 1979.

(17) Keinan, E.; Mazur, Y. *J. Org. Chem.* **1978**, *43*, 1020.

(18) Leibfritz, D.; Roberts, J. D. *J. Am. Chem. Soc.* **1973**, *95*, 4996.

Table I. Distances *d* (Å) between Guest C=O Group and Host (DCA or APA)

(a) DCA-Acetone								
C=O	DCA	<i>d</i> , 103 K	<i>d</i> , 293 K	C=O	DCA	<i>d</i> , 103 K	<i>d</i> , 293 K	
O(G1)	H5 ^a	3.0	3.0	C(G2)	C5	3.8	4.0	
	C5 ^a	3.9	4.0		C6 ^a	4.0	4.1	
	H6 _{eq} ^a	3.3	3.7	O(G3)	H5	2.9	3.0	
	H6 _{ax} ^a	4.1	3.9		C5	3.9	4.1	
C(G1)	C6 ^a	4.1	4.3	H6 _{eq} ^a	3.4	3.5		
	C5 ^a	3.8	3.9	H6 _{ax} ^a	3.3	3.1		
	C6 ^a	3.7	4.0	C6 ^a	3.7	3.9		
O(G2)	H5	2.7	3.0	C(G3)	C5	3.9	4.2	
	C5	3.8	4.0		C6 ^a	3.7	3.8	
	H6 _{eq} ^a	3.6	3.3					
	H6 _{ax} ^a	3.2	3.3					
	C6 ^a	3.8	3.9					
(b) APA-Acetone								
C=O	APA	<i>d</i> , 293 K	C=O	APA	<i>d</i> , 293 K			
O	H20	2.9	C	C20	4.5			
(c) DCA-Diethyl Ketone								
C=O	DCA	<i>d</i> , 293 K	C=O	DCA	<i>d</i> , 293 K			
O	H5	3.3	C	C5	4.2			
	C5	4.0		C6	3.8			
	H6 _{eq}	3.3						
	H6 _{ax}	3.9						
	C6	3.9						
(d) DCA-Cyclohexanone								
C=O	DCA ^b	<i>d</i> , 293 K	C=O	DCA ^b	<i>d</i> , 293 K			
O ^a	H16'	3.4	O	H16'	3.4			
	C16	4.3		C16	4.3			
C ^a	C16	4.4	C	C16	4.2			
(e) DCA-Ethyl Methyl Ketone								
C=O	DCA	<i>d</i> , 103 K	<i>d</i> , 293 K	C=O	DCA	<i>d</i> , 103 K	<i>d</i> , 293 K	
O(G) ^a	H5	2.8	3.2	O(G') ^a	H5	2.6	2.8	
	C5	3.7	3.9		C5	3.6	3.7	
	H6 _{eq}	3.5	3.2		H6 _{eq}	3.8	3.6	
	H6 _{ax}	3.7	3.9		H6 _{ax}	3.9	4.0	
	C6	3.7	3.9		C6	3.9	4.0	
C(G) ^a	C5	3.9	4.0	C(G')	C5	3.8	3.8	
	C6	3.6	3.7		C6	3.9	4.0	
(f) DCA-Methyl Pentyl Ketone								
C=O	DCA	<i>d</i> , 103 K	C=O	DCA	<i>d</i> , 103 K			
O(G) ^a	H5	2.9	O(G') ^a	H5	3.0			
	C5	3.9		C5	3.9			
	H6 _{eq}	3.6		H6 _{eq}	3.4			
	H6 _{ax}	3.9		H6 _{ax}	3.9			
	C6	4.3		C(G')	C5	4.1		
	C6	3.7			C6	4.2		

^aSymmetry operation $1/2 - x, -y, \pm 1/2 + z$ applied to atom. ^bThe first three entries correspond to molecule A of DCA; the next three to molecule B.

suggesting incorrect location of the guest molecule. In order to find the guest molecule, X-ray diffraction data were measured from a crystal cooled to a temperature of ca. 103 K.

Least-squares refinement (see section 5.3) yielded an $R = 0.072$. The channel was found to contain three independent acetone molecules G1, G2, G3, with individual occupancies (i.e., guest/host molar ratios) of 0.24 (1), 0.18 (1), and 0.24 (1) respectively, totaling 0.66 (2). Given the refined positions of G1, G2, and G3, one may construct only one feasible guest-packing motif shown in Figure 5. The arrangement comprises a chain of repeating close-packed triplets G1, G2, G3; the individual guest occupancies are 1:5, giving a total of 0.6. Keeping the occupancies of G1, G2, and G3 each fixed at 0.2, further structure refinement left R unchanged at 0.072.

The atomic x , y , and z coordinates of this structure were then used as a starting model for the refinement of the room-temperature crystal structure, yielding $R = 0.086$ (see section 5.3). The thermal motion of the acetone molecules is 0.12 \AA^2 , compared to 0.05 \AA^2 at 103 K. This result is in accord with solid-state NMR measurements on DCA-acetone.¹⁹

The guest molecules in the channel are approximately coplanar, so forming a ribbon whose plane is wedged between steroid rings A and B of the two opposite channel walls. These guest-host arrangements at the sites of reaction are shown in Figure 6. The corresponding guest-host distances at both temperatures (103 and 293 K) are listed in Table Ia. These distances at 103 K tend to be systematically shorter by an average value of 0.1 Å than the corresponding values at 293 K. This may be associated primarily with the reduction in length of the a axis by 0.4 Å on cooling the crystal (see Table IIa). It is not possible to conclude with certainty from Table Ia and Figure 6 which of the guest molecules G1, G2, or G3 reacts to form products 1, 2, or 3. What one may deduce is that guest C'=O...H—C(steroid) distances ranging from 3.0 to 3.4 Å, and the corresponding guest O'=C...C—H(steroid) distances as long as 4 Å lead to reaction.

3.2. APA-Acetone. In order to establish the geometrical parameters essential for the occurrence of intermolecular hydrogen abstraction, acetone was introduced into a different host channel environment, by complexing it with APA. The object was to compare its photochemical behavior with that of DCA-acetone.

The 1:1 APA-acetone complex (mp 168–172 °C) was prepared by crystallization of APA from acetone solution. The complex was light-stable (products <1%). The irradiation was performed under argon since APA is sensitive to oxygen and undergoes oxidations in the allylic positions when irradiated in air.

Crystal Structure of 1:1 APA-Acetone. Room-temperature X-ray data sufficed for the location of the acetone guest molecules because they are completely ordered in the channel and hence were unambiguously located (section 5.4). The channel cross section in APA-acetone (Figure 7) is appreciably larger than in DCA-acetone. This is because the APA bilayers juxtapose to form the β motif unlike DCA-acetone which appears in the α motif. The host-guest molar ratio is 1:1. The $>C'=O'$ moiety of acetone is perpendicular to the channel c axis; thus, acetone makes plane-to-plane contact of 3.6 Å along the c axis via twofold screw symmetry. The hydrogen atom H2O of the steroid side chain makes a contact of 2.9 Å with the guest oxygen atom. The corresponding distance between C20 and guest C'(carbonyl) is as long as 4.9 Å and the C20—H bond is almost parallel to the acetone C'=O' bond. Thus, the molecular environments of guest acetone in APA-acetone and DCA-acetone are completely different. The fact that the complex of APA is light-stable despite the presence of the short O'(guest)...H(host) contact emphasizes the topochemical nature of this solid-state reaction. We tentatively conclude that if the neighboring host (potentially reactive) C—H and guest C'=O' groups are close to collinear, no addition reaction occurs. There is an alternative explanation for the lack of reactivity. The guest molecule would have to rotate almost by a net 90° out of its stacking plane in order to form the bond between C20 and C' of acetone and so would probably incur, during rotation, prohibitively short contacts with neighboring unreacted guest molecules. No such constraint occurs in the channels of DCA-acetone where each guest molecule can easily bind to atoms C5 or C6 without inducing steric contacts with its neighboring guest molecules.

3.3. DCA-Diethyl Ketone. Further support for the topochemical nature of the ketone photoaddition reaction was provided by DCA-diethyl ketone. Here the host also crystallizes in the α motif, but the change in the guest molecule relative to acetone is sufficient to induce a different host-guest orientation.

DCA-diethyl ketone (2:1) (mp 148–150 °C) was prepared by crystallization of DCA from diethyl ketone. Irradiation of the complex under argon led to the formation of a single addition product 6 (~8%). Irradiation carried out in air yielded 6 and a hydroxylation product 7 (~8%) (Scheme IV).

Structure Assignment of Photoproducts. The structure assignment of compound 6 and its stereochemistry are based on its ¹³C NMR spectrum that showed a pronounced analogy to compound 1 obtained from the reaction of DCA with acetone.

Table II. Cell Constants and Experimental Data on X-ray Intensities of (a) DCA-Acetone, (b) APA-Acetone, (c) DCA-Diethyl Ketone, (d) DCA-Cyclohexanone, (e) DCA-Ethyl Ketone and (f) DCA-Methyl Pentyl Ketone

	a		b	c	d	e		f
crystal temp, K	103	293	293	293	293	103	293	103
formula								
host	C ₂₄ H ₄₀ O ₄	C ₂₄ H ₄₀ O ₄	C ₂₄ H ₃₈ O ₄	C ₂₄ H ₄₀ O ₄	C ₂₄ H ₄₀ O ₄	C ₂₄ H ₄₀ O ₄	C ₂₄ H ₄₀ O ₄	C ₂₄ H ₄₀ O ₄
guest	³ / ₅ (C ₃ H ₆ O)	³ / ₅ (C ₃ H ₆ O)	C ₃ H ₆ O	¹ / ₂ (C ₃ H ₁₀ O)	¹ / ₂ (C ₆ H ₁₀ O)	¹ / ₂ (C ₄ H ₈ O)	¹ / ₂ (C ₄ H ₈ O)	¹ / ₃ (C ₃ H ₁₀ O)
a (a), Å ^b	25.416 (4)	25.809 (5)	24.570 (5)	25.828 (2)	26.990 (3)	25.462 (5)	25.805 (5)	25.529 (4)
b	13.514 (4)	13.610 (3)	14.264 (3)	13.560 (1)	13.354 (1)	13.448 (5)	13.593 (2)	13.440 (3)
c	7.194 (6)	7.233 (1)	7.530 (1)	7.240 (1)	14.141 (2)	7.176 (4)	7.228 (1)	7.214 (1)
z	4	4	4	4	8	4	4	4
V, Å ³	2471	2541	2536	2536	5097	2457	2535	2475
space group	P2 ₁ 2 ₁ 2 ₁	P2 ₁ 2 ₁ 2 ₁	P2 ₁ 2 ₁ 2 ₁	P2 ₁ 2 ₁ 2 ₁	P2 ₁ 2 ₁ 2 ₁	P2 ₁ 2 ₁ 2 ₁	P2 ₁ 2 ₁ 2 ₁	P2 ₁ 2 ₁ 2 ₁
D _c , g/cm ³	1.15	1.12	1.13	1.14	1.15	1.16	1.12	1.15
mp, °C	170-175	170-175	168-172	148-150	157	170-175	170-175	168-170
diffractometer	CAD-4	Siemens	Siemens	Siemens	Siemens	CAD-4	Siemens	CAD-4
X-rays	Mo Kα	Cu Kα	Cu Kα	Cu Kα	Cu Kα	Mo Kα	Cu Kα	Mo Kα
μ, cm ⁻¹	0.8	6	6	6	6	0.8	6	0.8
crystal size of specimen, mm	1.5 × 4 × 4	1.5 × 1.5 × 4.7	2 × 4 × 9	1 × 3 × 5	1.4 × 1.5 × 4.0	2 × 4 × 5	1 × 2 × 3	2 × 2 × 5
θ range, deg	2-30	2-65	2-65	2-70	2-70	2-35	2-70	2-33
ω/θ scan ratio	1/1	1/1	1/1	1/1	1/1	2/1	1/1	3/2
max scan time, s	60	100	100	100	100	80	100	80
reflections measd	4109	4903	5081	5400	5442	6123	2770	5732
R _m ^c		0.07	0.04	0.063		0.037		0.043
no. of indep reflect	4109	2505	2579	2771	5442	6011	2770	4232
absorpt correct ^d	no	yes	yes	yes	yes	no	yes	no

^aThe guest-host molar ratios of compounds a-f are 3:5, 1:1, 1:2, 1:2, 1:2, and 1:3, respectively. ^bλ(Mo Kα₁) = 0.070926 Å, λ(Cu Kα₁) = 1.54051 Å. ^cR_m = Σ|F² - F²_w|/ΣF², where F is an observed structure factor and F_w the weighted mean of the corresponding symmetry-related set of observed structure factors. ^dCrystal X-ray absorption corrections were applied by the method given in ref 22.

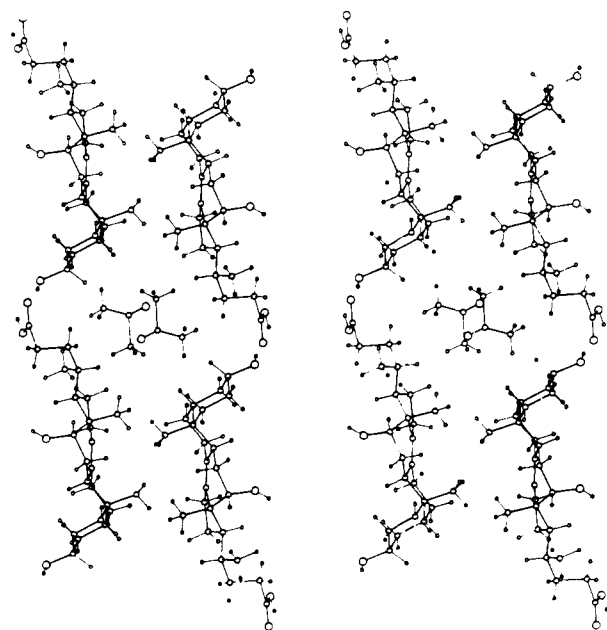
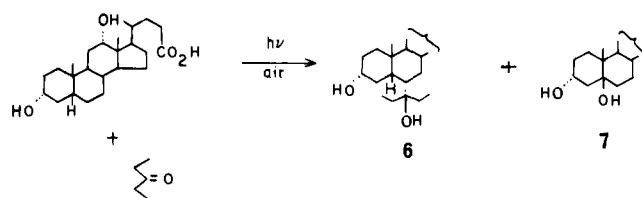
**Figure 7.** Stereoscopic view of the packing arrangement of APA-acetone.**Scheme IV**

Compound 6 was transformed to 5 by the same chemical modifications described for compounds 1 and 2.

The structure of compound 7 was assigned by comparison with the same product obtained from the reaction of DCA with *tert*-butyl diperoxymonocarbonate which has identical melting point, X-ray powder picture, and ¹³C NMR spectrum.¹²

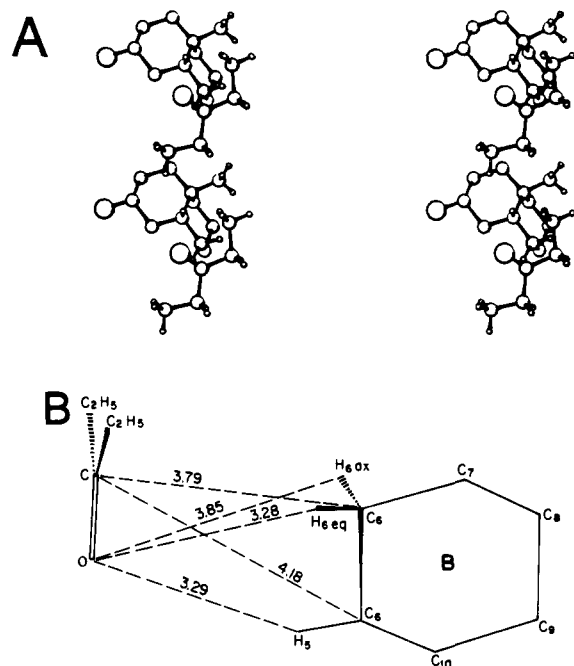
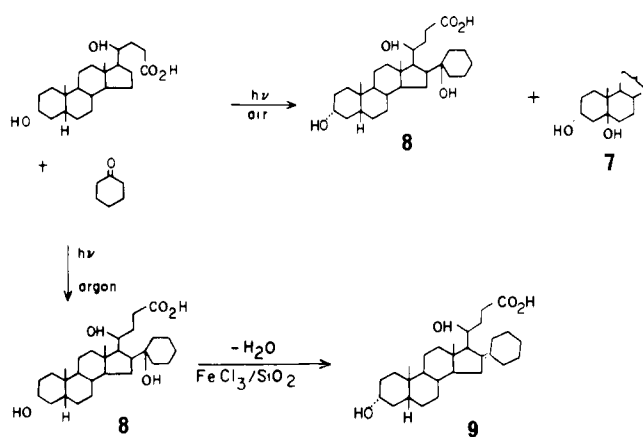

Figure 8. (A) DCA-diethyl ketone. Stereoscopic view of guest molecules along the channel as sandwiched between rings A and B of neighboring steroid molecules. H atoms attached to C5 and C6 are shown. (B) Distances between the atoms of the carbonyl group of diethyl ketone and sites C5-H, C6-H_{eq}, and C6-H_{ax}.

Crystal Structure and Reactivity. The structure of 2:1 DCA-diethyl ketone at room temperature was determined by X-ray diffraction (see section 5.5). The guest molecules in the channel are related by *c* translation with acceptable intermolecular C-(methyl)⋯C-(methyl) contacts of 4.3 Å, as shown in Figure 8A. The separation O'(guest)⋯H5(host) is 3.3 Å; however no addition product to C5 was formed presumably because of the long C'=O'(guest)⋯C5(host) distance of 4.2 Å (Table I_c and Figure 8B). Were addition to take place to C5 despite the "long" separation of 4.2 Å, there would need be a displacement of approximately 2.5 Å of the to-be-reacted guest molecule along the channel axis,

Scheme V



Scheme VI

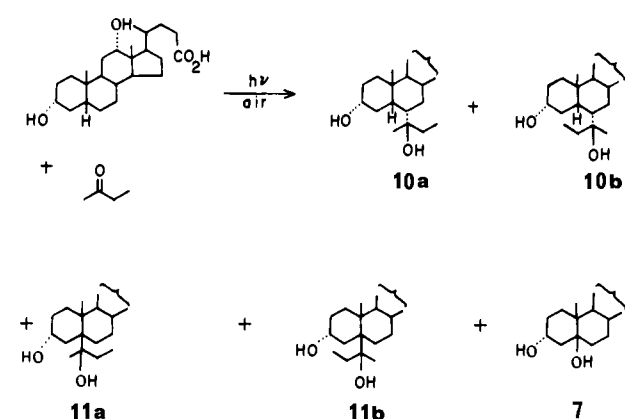

leading to an impossibly short contact between it and a neighboring guest molecule as may be deduced from Figure 8A. On the other hand, photoaddition to atom C6 via H6_{eq} would induce a negligible shift of the to-be-reacted guest molecule along the channel axis to permit normal intermolecular contacts. The preclusion of photoaddition of the guest ketone to C5 suggests that the radical formed on C5 may be trapped by molecular oxygen available in the channel leading to the isolated C5-OH hydroxy product 7.

3.4. DCA-Cyclohexanone. The DCA complexes described above, which are all of the α type, contain linear paraffinic ketone guests sandwiched between rings A and B, from which hydrogen abstraction takes place. At this stage we considered ways by which it would be possible to functionalize ring D or the steroid side chain. We had previously observed¹² that the bulky guest molecule di-*tert*-butyl diperoxydicarbonate induced a channel in which the guest is sandwiched between ring D and its side chain. The cross section of this channel labeled the γ type is significantly different to that of the α type (see section 2). Thus, to induce DCA to adopt the γ motif, it was necessary to choose a bulky ketone guest; cyclohexanone, and derivatives thereof, proved to be an auspicious choice.¹⁷ DCA-cyclohexanone (2:1) (mp 156.8 °C) was prepared by cocrystallization of DCA with cyclohexanone from methanol solution containing an excess of cyclohexanone. Irradiation of the complex under argon led to the formation of a topochemical addition product 8 (6%). When irradiation was carried out in air, both products 8 (6%) and 7 (10%) were formed (Scheme V).

Structure Assignment of Photoproducts. The structure of 8 was assigned according to its ¹³C NMR spectrum and degradation in the mass spectrum of compound 9. The ¹³C NMR spectrum of 8 shows that no change occurred in the region of rings A and B of the steroid while a significant shift of +2.6 ppm at C18 indicates that the addition occurred at rings C or D. The large shifts of +5.5 ppm at C17 and +5.5 at C15 strongly support the addition to position C16 of the steroid. The strong influence of

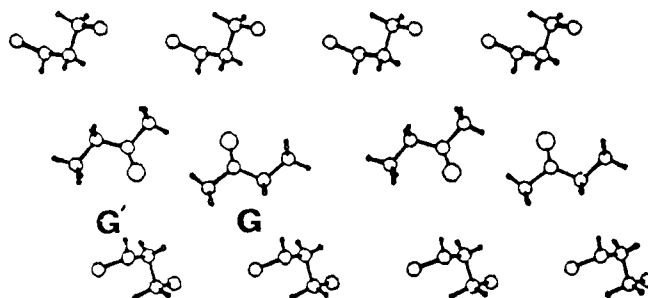

Figure 9. Packing of ethyl methyl ketone molecules in the DCA channel. Part of the steroid side chain (i.e., atoms C20, C21, C22, C23, C24, and some attached H atoms) forming the channel wall is shown.

+2.6 ppm on C18 and the shift of -2.3 ppm on C20 indicate that 8 is the C16 isomer. Compound 8 and its methyl ester decomposed under the mass spectrometric conditions. Thus, 8 was dehydrated on SiO_2 -supported $FeCl_3$ to give 9 whose methyl ester showed a molecular peak m/e 486 and a characteristic peak m/e 343 arising from the loss of the cyclohexyl ring and C15 and C16 of ring D of the steroid.

Crystal Structure and Reactivity. The crystal structure of 2:1 DCA-cyclohexanone (at 293 K) was refined to $R = 0.09$ (see section 5.8). Each guest atom was unambiguously and easily located by virtue of the lack of guest disorder. The channel is of the γ type (Figure 4C). The guest carbonyl group $C=O$ is in close proximity to ring D and the side chain of the two independent steroid molecules A and B. The steroid position 16_{ax} of both steroid molecules is the most eligible candidate for photoaddition in terms of both $O'\cdots H16_{ax}$ and $C'\cdots C16$ contacts, although the distance of 4.2 Å between C16 and C' appears to be unusually long for the reaction to occur (see Table Id).

3.5. DCA-Ethyl Methyl Ketone and DCA-Methyl Pentyl Ketone. The DCA complexes described above contain symmetrically substituted ketones as the guest. The stereospecificity of the reactions was studied in terms of the host-guest orientations and distances in the complex prior to reaction. We now probe the photoaddition reaction by using prochiral ketones $R_1R_2C=O$ as the guest. Such ketones allow one to probe the molecular pathway insofar as photoaddition to the steroid leads to formation of a new chiral carbon center whose absolute configuration may be compared with the prochiral arrangement about the guest carbonyl carbon atom before reaction. The simplest prochiral ketone chosen was ethyl methyl ketone.

The 2:1 complex between DCA and ethyl methyl ketone (mp 170-175 °C) was prepared by crystallization of DCA from the ethyl methyl ketone solution. Irradiation of the complex in air led to the formation of two diastereomeric pairs of addition products 10a and 10b (16%), 11a and 11b (12%), and the hydroxylation product 7 (12%). When the crystallization and the reaction were performed under argon, 7 was not formed (Scheme VI).

Structure Assignment of Photoproducts from DCA-Ethyl Methyl Ketone. The mixtures of diastereomeric pairs 10a and 10b and 11a and 11b could not be separated by chromatographic methods, and they could be detected only by ¹³C NMR spectroscopy, since different chemical shifts were observed for carbon atoms close to the new chiral centers produced in the two diastereomers.

Compounds 10a and 10b were assigned to be products of addition to position 6_{eq} of the steroid by comparing the ¹³C NMR spectrum to that of the analogous compounds 1 and 6 obtained from the reactions of acetone and diethyl ketone, respectively. Similarly, the mixture 11a and 11b was assigned to be products of addition to position 5 by comparing the ¹³C NMR spectrum with that of compound 3 obtained from reaction of acetone.

Structure Assignment of Photoproducts from DCA-Methyl Pentyl Ketone. The 3:1 complex of DCA and ethyl pentyl ketone (mp 168-170 °C) was prepared by crystallization of DCA from methyl pentyl ketone solution. Irradiation of the complex in air led to the formation of addition products 1, 2, 3, and the hy-

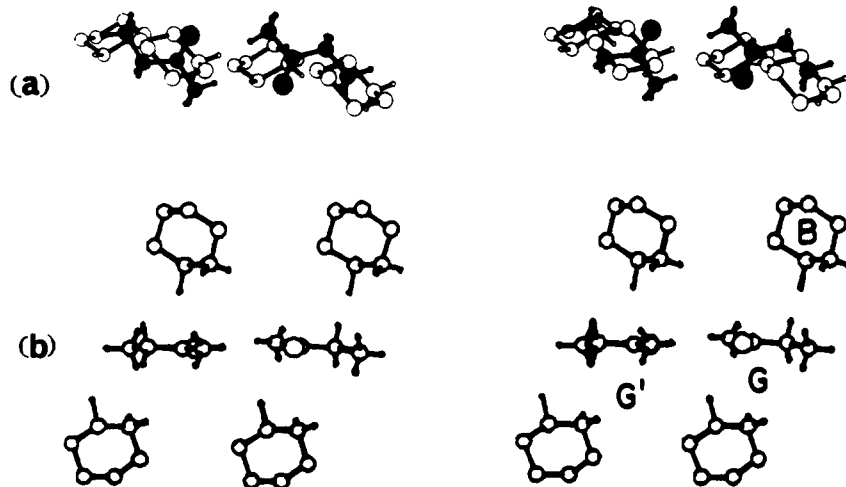

Figure 10. Dimer of ethyl methyl ketone molecules G and G' sandwiched between steroid rings. The steroid H atoms attached to C5 and C6 are shown. Stereoscopic views from (a) top and (b) side.

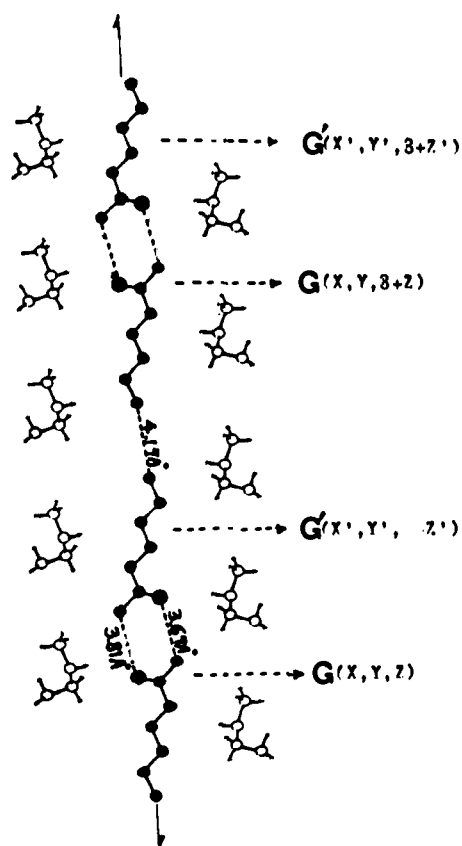

Figure 11. Arrangement of methyl pentyl ketone dimer molecules G and G' in a DCA channel.

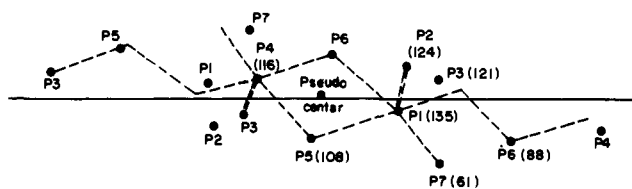

Figure 12. DCA-methyl pentyl ketone. Peak distribution and relative heights from an electron density difference map. Two guest molecules were constructed from these peaks.

droxylation product 7. In the absence of oxygen, only products 1, 2, and 3 were formed, isolated and identified by comparison with the photoproducts obtained from the photoirradiation of the complex DCA acetone (Scheme I). These observations indicate

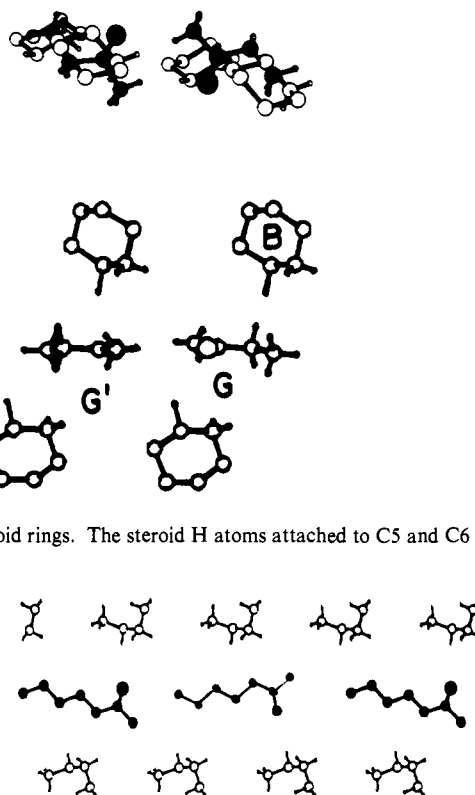
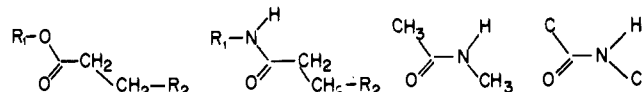

Figure 13. Methyl pentyl ketone G' molecules related by 2_1 symmetry forming a nearest-neighbor arrangement in a DCA channel.

Scheme VII



that methyl pentyl ketone undergoes a photocleavage to acetone, which subsequently reacts with DCA to yield the same photoproducts as acetone. This reaction was not further investigated. Analogous photocleavage of an aliphatic ketone occluded in the channels of a urea complex has been recently reported.²⁰

Crystal Structure and Reactivity. The X-ray diffraction data of 2:1 DCA-ethyl methyl ketone were measured from a crystal at 293 K and also at 103 K in order to better locate the guest molecules. The crystal structure belongs to the α motif (Figure 4A). According to the low-temperature structure analysis (section 5.7), the channel contains two independent guest molecules G and G' per asymmetric unit. They form pseudocentrosymmetric dimers related by a translation repeat of $2c$ along the channel axis (Figure 9), resulting in a host-guest molar ratio of 2:1. The atomic x , y , and z coordinates of this structure were used as a starting model for refinement of the room-temperature structure (section 5.7).

The geometry of contact between the guest molecules G and G' and steroid rings A and B (see Figure 10 and Table Ie) is completely compatible with the formation of the diastereomeric pairs 10a and 10b and 11a and 11b (Scheme VI); the reactive centers of the steroid at atoms C5 and C6 are equally well exposed to the opposite faces of G and G'.

The crystal structure of 3:1 DCA-methyl pentyl ketone (section 5.6) is very similar to that of DCA-ethyl methyl ketone. The channel of the former contains two independent guest molecules G and G' per asymmetric unit. They form dimers related by a translation repeat of $3c$ along the channel axis (Figure 11), resulting in a host-guest molar ratio of 3:1. The $-\text{CH}_2-\text{COCH}_3$ dimer moieties of methyl pentyl ketone occupy the same location in the channel as the corresponding guest ethyl methyl ketone

(20) Casal, H. L.; de Mayo, P.; Miranda, J. F.; Scaiano, J. C. *J. Am. Chem. Soc.* 1983, 105, 1983.

Scheme VIII

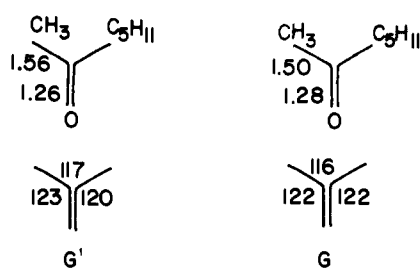

Scheme IX

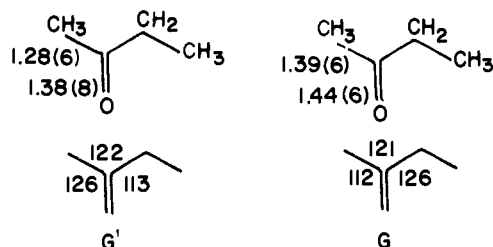

dimer. This result indicates that the location of the methyl alkyl ketone dimer along the channel is determined by the contacts between host and the dimer.

4. Discussion and Conclusion

The present study clearly demonstrates that the guest ketone molecules occupy defined crystallographic sites and orientations, induced by host-guest and guest-guest contacts. The crystallographic results indicate that the guest molecules at room temperature undergo pronounced thermal motion yet still functionalize stereospecifically to the steroid host. The photochemical results imply that photoaddition takes place with substantial rearrangement and change in molecular structure at the site of to-be-reacted guest. It was found possible to introduce the guest ketone into different channel motifs (i.e., α , β , and γ), so as to functionalize, but within limits, different remote sites of the host.

The α motif is induced by nonbulky guest molecules when cocrystallized with DCA, the γ motif by relatively bulky guests. The channel cross section in the α motif is smaller than in the γ motif, as manifested by the smaller length of the a axis of the former (25.6 vs. 26.9 Å). In the α motif, the two opposite wide walls of the channel comprise the fused rings A and B, the two narrow walls the steroid side chain attached to ring D. The two wide walls in the γ motif comprise ring D and its side chain; the narrower walls are formed by part of rings A and B. The guest aliphatic ketones in the α motif are sandwiched between the A,B ring moieties; in the γ motif the ketone molecules are sandwiched by ring D and its side chain. The guest ketones react photochemically only with those C atoms on the channel wall and whose exposed C-H bonds are directed toward the channel. The photoaddition takes place by abstraction of the steroid H atom by the ketone oxygen O', followed by bond formation between the guest carbonyl atom C' and the steroid C atom.

Photoaddition was found to occur between guest C'=O' and the steroid C-H group when the distances from atom O' to C and from C' to C were as long as 3.4 and 4.2 Å, respectively,

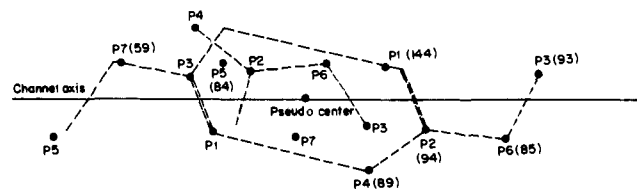

Figure 14. DCA-ethyl methyl ketone. Peak distribution and relative heights from an electron density difference map. Two guest molecules were constructed from the peaks.

implying a high degree of reorganization during reaction. According to the packing diagrams, the angle between the plane of the guest ketone moiety $>C=O'$ and the steroid C-H bond of the to-be-abstracted H varies over a wide angular range from about 50° to 90° .

Photoaddition was found to occur at sites C5 and C6 in the α motif, these atoms being centrally located on the wide channel wall. Photoaddition does not occur at sites on the steroid side chain comprising the narrow channel wall; these sites are relatively far removed from the guest ketone C'=O' group. By similar reasoning we account for photoaddition to site C16 in the γ motif. This atom is centrally located on the wide channel wall.

The photochemical studies have indicated that the addition reactions are topochemically controlled but appear to depend also on the orientation of the $>C=O'$ moiety of the guest molecule with regard to the steroid C-H bond as well as on the fit between nearest-neighbor guest molecules in the channel. Use of the prochiral methyl alkyl ketone guests for comparison between the stereochemistry of the host-guest arrangement at the reaction site and the absolute configuration of the newly generated chiral C center of the photoproduct proved to be unsuccessful. This is because the methyl alkyl ketone guest molecules form cyclic quasi-centrosymmetric dimers in the channel leading to diastereomeric photoproducts, and so it is hardly possible to deduce which guest yields which diastereomeric product.

Hydroxylation at position C5 was found to take place when geometric conditions were satisfied for abstraction of H5 by the guest ketone to occur but could not be followed by bond formation between C5 and the ketone. The hydroxylation reaction involved occluded molecular O₂ in the channel.

Having established the feasibility for performing stereo- and regioselective reactions in these complexes, we exploited such systems to elucidate the molecular pathway of the photoaddition step by using prochiral aromatic ketones as the guest. This work will be described in the following papers in this series.

5. Experimental Section

5.1. General Chemical Procedure. All complexes have been prepared by cocrystallization of DCA with the guest, using the guest as solvent for crystallization, except for the complex with cyclohexanone, where absolute methanol was used as solvent. The crystallizations were carried out by slow evaporation of the solvents. The approximate host-guest ratios were determined by the integration in their ¹H NMR spectra.

In a characteristic experiment, 5–10 g of the complex was irradiated at room temperature through Pyrex dishes $\lambda \gg 290$ nm for about 10 days. The crystals were in powder form. Single crystals preserve their integrity upon irradiation. The irradiation products were separated by chromatography on silica gel 1:100 and eluted with CH₂Cl₂/CH₃OH/AcOH in a ratio of 94.5:5.0:0.5. The products were detected by TLC

Table III. Structure-Factor Refinement for (a) DCA-Acetone (103 K), (b) DCA-Acetone (293 K), (c) APA-Acetone (293 K), (d) DCA-Diethyl Ketone (293 K), (e) DCA-Cyclohexanone (293 K), (f) DCA-Ethyl Methyl Ketone (103 K), (g) DCA-Ethyl Methyl Ketone (293 K), and (h) DCA-Methyl Pentyl Ketone (103 K)

	a	b	c	d	e	f	g	h
no. refined parameters	432	416	253	289	505	426	426	426
criterion for F_{obsd} exclusion	$F < 3\sigma(F)$	$F < 3\sigma(F)$	$F < 1.4\sigma(F)$	$F < 1.4\sigma(F)$	$F < 1.4\sigma(F)$	$F < 3\sigma(F)$	$F < 3\sigma(F)$	$F < 2\sigma(F)$
no. of F_{obsd} in refinement	1877	1851	2264	2485	4490	2961	1867	2723
weighting scheme	$1/\sigma^2(F)$	1	$1/\sigma^2(F)$	$1/\sigma^2(F)$	$1/\sigma^2(F)$	$1/\sigma^2(F)$	$1/\sigma^2(F)$	$1/\sigma^2(F)$
R^a	0.072	0.086	0.083	0.108	0.086	0.097	0.097	0.058
R_w^a	0.067	0.067				0.096	0.105	0.056

^a $R = \sum |F_o - |F_c|| / \sum F_o$. $R_w = \sum w^{1/2} |F_o - |F_c|| / \sum w^{1/2} F_o$.

Table IV. Deoxycholic Acid-Acetone (103 K): (a) x , y , and z Coordinates ($\times 10^4$) and U_{eq}^a ($\times 10^3$, \AA^2) of the C and O Atoms of Deoxycholic Acid (Average $\sigma(U_{\text{eq}}) = 0.004 \text{\AA}^2$), (b) x , y , and z Coordinates ($\times 10^4$) and Isotropic U (\AA^2 , $\times 10^3$) of H Atoms of Deoxycholic Acid (Average $\sigma(U) = 0.012 \text{\AA}^2$. Average $\sigma(x)$, $\sigma(y)$, and $\sigma(z) = 20, 40$, and 70 ($\times 10^4$), respectively), (c) x , y , and z Coordinates ($\times 10^4$) of the Guest Acetone Molecules^a G1, G2, and G3 (The Isotropic U of each Atom = 0.053 (3) \AA^2)

(a) x , y , z , and U_{eq} of C and O Atoms of Deoxycholic Acid									
atom	x	y	z	U_{eq}	atom	x	y	z	U_{eq}
C(1)	1229 (3)	2 170 (4)	3542 (9)	30	C(15)	1628 (3)	5 648 (4)	-2491 (9)	30
C(2)	677 (3)	1 897 (4)	2946 (8)	29	C(16)	1373 (3)	6 687 (4)	-2330 (9)	30
C(3)	698 (3)	1 181 (4)	1363 (9)	32	C(17)	1079 (3)	6714 (4)	-443 (8)	22
C(4)	996 (3)	1 619 (4)	-275 (8)	28	C(18)	1868 (3)	6 189 (4)	1443 (9)	30
C(5)	1556 (3)	1 927 (4)	289 (9)	32	C(19)	2122 (3)	2 764 (5)	2726 (11)	41
C(6)	1861 (3)	2 365 (4)	-1371 (10)	34	C(20)	1078 (3)	7 775 (4)	380 (8)	26
C(7)	1660 (3)	3 380 (4)	-1938 (9)	30	C(21)	802 (3)	7850 (4)	2240 (9)	32
C(8)	1637 (3)	4101 (4)	-305 (9)	28	C(22)	846 (3)	8 529 (5)	-1020 (9)	28
C(9)	1332 (3)	3 660 (4)	1344 (9)	25	C(23)	285 (3)	8 357 (5)	-1568 (9)	34
C(10)	1558 (3)	2 649 (4)	1975 (9)	30	C(24)	89 (3)	9 161 (4)	-2876 (8)	29
C(11)	1260 (3)	4 420 (4)	2915 (8)	27	O(25)	165 (2)	952 (3)	830 (6)	36
C(12)	1013 (3)	5 396 (4)	2253 (8)	24	O(26)	481 (2)	5 205 (3)	1641 (6)	27
C(13)	1337 (3)	5 862 (4)	662 (8)	24	O(27)	84 (2)	10 045 (3)	-2482 (6)	48
C(14)	1382 (3)	5 077 (4)	-900 (9)	26	O(28)	-72 (2)	8 832 (3)	-4473 (7)	35

(b) x , y , z , and U of H Atoms of Deoxycholic Acid					(c) x , y , z , and U of Guest Molecules				
atom	x	y	z	U	atom	x	y	z	U
H(1)	1258	2 577	4 637	37	Molecule G1 [$\sigma(x)$, $\sigma(y)$, $\sigma(z) = 11, 23, 35$ ($\times 10^4$), respectively]				
H(1')	1419	1 534	3 820	37	O(1)	2630	519	4970	
H(2)	495	1 587	3 995	13	C(1)	1888	-502	5 307	
H(2')	441	2 478	2 348	13	H(1)	1791	-430	6 489	
H(3)	884	548	1 588	5	H(2)	1659	-499	4 342	
H(4)	781	2 228	-712	36	H(3)	2015	-1114	4 871	
H(4')	974	1 069	-1 158	36	C(2)	2340	-77	4 229	
H(5)	1743	1 355	801	25	C(3)	2378	-300	2 224	
H(6)	2224	2 515	-1 007	51	H(4)	2006	-277	1 755	
H(6')	1839	1 944	-2 454	51	H(5)	2529	-957	2 400	
H(7)	1292	3 323	-2 334	19	H(6)	2605	229	1 432	
H(7')	1917	3 566	-2 891	19	Molecule G2 [$\sigma(x)$, $\sigma(y)$, $\sigma(z) = 9, 18, 36$ ($\times 10^4$), respectively]				
H(8)	1941	4 158	141	5	O(1)	2252	-493	11 237	
H(9)	976	3 501	858	0	C(1)	2817	231	9 036	
H(11)	1082	4 097	3 907	15	H(1)	2579	38	8 202	
H(11')	1617	4 479	3 684	15	H(2)	2962	849	9 062	
H(12)	1013	5 898	3 280	6	H(3)	3157	-30	9 011	
H(14)	1019	4 928	-1 266	8	C(2)	2633	30	10 983	
H(15)	2013	5 654	-2 550	20	C(3)	2928	466	12 542	
H(15')	1547	5 361	-3 710	20	H(4)	2898	1201	12 289	
H(16)	1089	6 756	-3 271	26	H(5)	3279	192	12 507	
H(16')	1647	7 181	-2 389	26	H(6)	2688	301	13 740	
H(17)	713	6 504	-620	0	Molecule G3 [$\sigma(x)$, $\sigma(y)$, $\sigma(z) = 9, 19, 33$ ($\times 10^4$), respectively]				
H(18)	2076	6 558	528	37	O(1)	2210	-313	2 869	
H(18')	2109	5 668	1 725	37	C(1)	2742	565	4 969	
H(18'')	1807	6 618	2 519	37	H(1)	2511	329	5 809	
H(19)	2359	3 073	1 819	51	H(2)	3089	581	5 144	
H(19')	2298	2 185	3 139	51	H(3)	2755	1247	4 724	
H(19'')	2179	3 213	3 711	51	C(2)	2610	166	3 080	
H(20)	1471	7 967	417	1	C(3)	2986	324	1 550	
H(21)	1001	7 526	3 256	20	H(4)	3301	-111	1 780	
H(21')	434	7 496	2 337	20	H(5)	3044	1032	1 714	
H(21'')	751	8 575	2 587	20	H(6)	2799	80	271	
H(22)	1043	8 452	-2 181	28					
H(22')	885	9 207	-434	28					
H(23)	45	8 375	-504	32					
H(23')	241	7 760	-2 265	32					
H(25)	116	811	-369	47					
H(26)	259	5 318	2 609	48					
H(28)	-223	9 257	-5 002	25					

^a Equivalent temperature factor $U_{\text{eq}} = 1/3 \sum_{ij} U_{ij} a_i^* a_j^* a_i a_j$. ^b Each acetone molecule was refined as a rigid body; thus all atoms of each molecule have the same $\sigma(x)$, $\sigma(y)$, and $\sigma(z)$.

by using eluent $\text{CH}_2\text{Cl}_2/\text{CH}_3\text{OH}/\text{AcOH}$ in a ratio of 90.5:9.0:0.5 and phosphormolybdic acid as the coloring spray. Methyl esters of the products were prepared by esterification with diazomethane.

Compound 1: TLC $R_f = 0.3$ (DCA has $R_f = 0.6$); mp 175–180 °C (crystallized from methanol/methylene chloride); mass spectrum (methyl ester), m/e 464 (M^+), 446 ($\text{M} - \text{H}_2\text{O}$), 428 ($\text{M} - 2\text{H}_2\text{O}$), 410 ($\text{M} - 3\text{H}_2\text{O}$), 385 ($\text{C}_{25}\text{H}_{37}\text{O}_3$), 355 ($\text{M} - 2\text{H}_2\text{O} - \text{ring A}$), 313 ($\text{M} - 2\text{H}_2\text{O} - \text{side chain}$), 295 ($\text{M} - 3\text{H}_2\text{O} - \text{side chain}$), $^1\text{H NMR}$ (CD_3OD) δ 0.70 (3 H, s, 18-H), 0.95 (3 H, d, $J = 6$ Hz, 21-H), 1.10 (3 H, s, 19-H), 1.28 (3 H, s, $\text{CH}_3\text{C}(\text{OH})\text{CH}_3$), 1.35 (3 H, s, $\text{CH}_3\text{C}(\text{OH})\text{CH}$).

Compound 2: TLC $R_f = 0.55$; mp 213–215 °C (methanol/methylene chloride); mass spectrum (methyl ester), m/e 464 (M^+), 446 ($\text{M} - \text{H}_2\text{O}$),

428 ($\text{M} - 2\text{H}_2\text{O}$), 410 ($\text{M} - 3\text{H}_2\text{O}$), 395 ($(\text{C}_{25}\text{H}_{37})_3$), 355 ($\text{M} - 2\text{H}_2\text{O} - \text{ring A}$), 313 ($\text{M} - 2\text{H}_2\text{O} - \text{side chain}$), 295 ($\text{M} - 3\text{H}_2\text{O} - \text{side chain}$); $^1\text{H NMR}$ (CD_3OD) δ 0.69 (3 H, s, 18-H), 1.0 (3 H, d, $J = 5.5$ Hz, 21-H), 1.04 (3 H, s, 19-H), 1.22 (3 H, s, $\text{CH}_3\text{C}(\text{OH})\text{CH}_3$), 1.24 (3 H, s, $\text{CH}_3\text{C}(\text{OH})\text{CH}$).

Compound 3: TLC $R_f = 0.45$; mp 218–221 °C (methanol/acetic acid); mass spectrum (methyl ester), m/e 404 ($\text{M} - \text{C}_3\text{H}_8\text{O}$), 386 ($\text{M} - \text{C}_3\text{H}_8\text{O} - \text{H}_2\text{O}$), 368 ($\text{M} - \text{C}_3\text{H}_8 - 2\text{H}_2\text{O}$), 255 ($\text{M} - \text{C}_3\text{H}_8\text{O} - 2\text{H}_2\text{O} - \text{side chain}$), 59 ($\text{C}_3\text{H}_7\text{O}$); $^1\text{H NMR}$ (CD_3OD) δ 0.69 (3 H, s, 18-H), 1.1 (3 H, s, 19-H), 1.3 (3 H, s, $\text{CH}_3\text{C}(\text{OH})\text{CH}_3$), 1.35 (3 H, s, $\text{CH}_3\text{C}(\text{OH})\text{CH}$).

Compound 4. This compound was prepared according to the procedure

Table V. (APA) Apocholic Acid-Acetone (at 293 K): *x*, and *y*, and *z* Coordinates ($\times 10^4$ for C and O and $\times 10^3$ for H)

atom	<i>x</i>	<i>y</i>	<i>z</i>	atom	<i>x</i>	<i>y</i>	<i>z</i>
Apocholic Acid							
C(1)	6412 (3)	-1911 (5)	2981 (9)	C(2)	5868 (3)	-2405 (5)	2872 (8)
C(3)	5863 (3)	-3083 (5)	1316 (9)	C(4)	5994 (2)	-2581 (4)	-394 (8)
C(5)	6548 (2)	-2085 (4)	-275 (8)	C(6)	6677 (2)	-1608 (5)	-2056 (9)
C(7)	6321 (3)	-742 (4)	-2401 (8)	C(8)	6300 (2)	-90 (4)	-858 (8)
C(9)	6187 (2)	-553 (4)	941 (7)	C(10)	6576 (2)	-1383 (4)	1269 (9)
C(11)	6158 (3)	150 (4)	2451 (8)	C(12)	5913 (2)	1094 (4)	1907 (8)
C(13)	6263 (2)	1558 (4)	432 (8)	C(14)	6319 (2)	836 (4)	-1088 (8)
C(15)	6328 (3)	1340 (5)	-2822 (8)	C(16)	6275 (3)	2389 (5)	-2358 (9)
C(17)	6007 (2)	2414 (4)	-500 (8)	C(18)	6824 (2)	1798 (4)	1195 (11)
C(19)	7165 (2)	-1033 (5)	1495 (2)	C(20)	6065 (2)	3375 (4)	376 (10)
C(21)	5768 (4)	3409 (5)	2215 (10)	C(22)	5883 (2)	4187 (5)	-807 (10)
C(23)	5273 (3)	4128 (5)	-1296 (11)	C(24)	5127 (2)	4958 (6)	-2472 (11)
C(25)	5319 (2)	-3473 (3)	1230 (7)	C(26)	5367 (1)	968 (3)	1290 (5)
O(27)	5100 (2)	5765 (4)	-2034 (7)	C(28)	5027 (2)	4703 (3)	-4115 (6)
H(1)	642	-147	398	H(1')	671	-241	318
H(2)	560	-191	263	H(2')	580	-270	403
H(3)	621	-356	157	H(4)	571	-208	-57
H(4')	600	-300	-144	H(5)	681	-260	3
H(6)	664	-208	-303	H(6')	708	-142	-198
H(7)	594	-96	-266	H(7')	647	-41	-348
H(9)	582	-81	69	H(11)	654	25	292
H(11')	594	-13	343	H(12)	591	154	294
H(15)	601	116	-357	H(15')	667	123	-350
H(16)	607	274	-325	H(16')	666	267	-229
H(17)	562	225	-68	H(18')	686	240	182
H(18')	708	195	31	H(18'')	704	130	172
H(19)	731	-70	249	H(19')	742	-152	143
H(19'')	734	-71	33	H(20)	646	346	65
H(21)	590	310	312	H(21')	537	312	228
H(21'')	572	405	283	H(22)	592	482	-19
H(22')	607	422	-198	H(23)	507	417	-10
H(23')	521	352	-193	H(25)	528	-377	10
H(26)	510	124	214	H(28)	493	522	-491
Acetone							
C(1)	7248 (6)	5277 (8)	4847 (15)	C(2)	7272 (6)	4173 (8)	4588 (15)
C(3)	6747 (6)	5523 (8)	5241 (15)	O(1)	7587 (6)	5568 (8)	43880 (15)
H(2)	692	390	494	H(2')	754	389	545
H(2'')	734	395	338	H(3)	671	619	538
H(3')	668	522	646	H(3'')	648	528	439

of Keinan and Mazur¹⁷ by dehydration of compounds **1** and **2** on SiO₂-supported FeCl₃; mp 212–214 °C (methanol); mass spectrum (methyl ester), 446 (M⁺), 428 (M - H₂O), 410 (M - 2H₂O), 395 (M - 2H₂O - Me), 355 (M - 2H₂O - ring A), 313 (M - 2H₂O - side chain), 295 (M - 3H₂O - side chain), 115 (side chain) ¹H NMR (CD₃CO₂D) δ 0.71 (3 H, s, C18-H), 0.78 (3 H, s, 19-H), 1.66 (6 H, s, C(CH₃)₂); ¹³C NMR (CD₃CO₂D) δ 35.7 (C1), 31.2 (C2), 72.7 (C3), 35.9 (C4), 47.3 (C5), 124.0 (C6), 29.1 (C7), 37.9 (C8), 34.7 (C9), 36.6 (C10), 30.0 (C11), 74.8 (C12), 47.6 (C13), 49.1 (C14), 24.6 (C15), 28.4 (C16), 47.9 (C17), 13.1 (C18), 23.2 (C19), 36.3 (C20), 17.5 (C21), 31.6 (C22 and C23), 133.0 (C(CH₃)₂), 31.6, 29.7 (C(CH₃)₂).

Compound 5. This compound was prepared from compound **4** by esterification with MeOH/HCl, diacetylation in acetic anhydride and pyridine, and oxidation with RuO₄. RuO₄ was prepared from RuO₂ and NaIO₄ in aqueous solution and extracted with CCl₄. The procedure is according to D. G. Lee:²¹ mass spectrum, *m/e* 504 (M⁺), 444 (M - A₂OH), 384 (M - 2A₂OH), 269 (M - 2A₂OH - side chain), 121, 95 (see Scheme III); ¹H NMR (CDCl₃) δ 0.73 (3 H, s, 18-H), 0.84 (3 H, s, 19-H), 2.0 (3 H, s, CH₃C), 2.1 (3 H, s, CH₃C), 3.6 (3 H, s, OCH₃).

Compound 6: TLC *R_f* = 0.4; mp 190–195 °C (methanol/methylene chloride); mass spectrum (methyl ester), *m/e* 492 (M⁺), 474 (M - H₂O), 456 (M - 2H₂O), 445 (M - H₂O - Et), 427 (M - 2H₂O - Et), 409 (M - 3H₂O - Et), 323 (M - 3H₂O - side chain), 87 (C₅H₁₁O); ¹H NMR (CD₃OD) δ 0.71 (3 H, s, 18-H), 0.9 (3 H, s, 19-H).

Compound 7: TLC *R_f* = 0.3; mp 165–167 °C (methanol); mass spectrum (methyl ester), *m/e* 422 (M⁺), 404 (M - H₂O), 386 (M - 2H₂O), 368 (M - 3H₂O), 332 (C₂₁H₃₂O₃), 289 (M - H₂O - side chain), 271 (M - 2H₂O - side chain), 261 (C₁₇H₂₆O₂), 253 (M - 3H₂O - side chain), 115 (side chain); ¹H NMR (CD₃OD) δ 0.72 (3 H, s, 18-H), 0.87 (3 H, s, 19-H); ¹³C NMR (CD₃OD) δ 36.9 (C1), 29.3 (C2), 69.2 (C3),

41.4 (C4), 78.0 (C5), 30.45 (C6), 29.3 (C7), 37.25 (C8), 36.2 (C9), 40.15 (C10), 29.6 (C11), 74.7 (C12), 47.2 (C13), 49.0 (C14), 24.6 (C15), 28.4 (C16), 47.8 (C17), 13.0 (C18), 16.6 (C19), 36.4 (C20), 17.5 (C21), 31.65 (C22), 31.6 (C23).

Compound 8: TLC *R_f* = 0.55; mp 200–205 °C dec; ¹H NMR (C-D₃OD) δ 0.87 (3 H, s, 18-H), 0.9 (3 H, s, 19-H); ¹³C NMR (CD₃OD) δ 36.0 (C1), 30.8 (C2), 73.0 (C3), 36.4 (C4), 43.3 (C5), 27.0 (C6), 28.1 (C7), 36.5 (C8), 35.0 (C9), 35.1 (C10), 29.0 (C11), 75.1 (C12), 47.8 (C13), 49.6 (C14), 30.3 (C15), 30.8 (C16), 53.5 (C17), 15.9 (C18), 23.5 (C19), 34.3 (C20), 17.9 (C21), 32.7 (C22), 32.4 (C23), 77.1 (cyclohexyl C-OH), 47.2, 39.0 (*o*-C atoms of cyclohexyl), 22.8, 22.7 (*m*-C atoms of cyclohexyl), 26.5 (*p*-C atoms of cyclohexyl).

Compound 9. Compound **8** was dissolved in ether mixed with silica gel impregnated with FeCl₃·6H₂O¹⁷ to yield, quantitatively, compound **9**: mass spectrum (methyl ester), *m/e* 486.3693 (M⁺, C₃₁H₅₀O₄, calcd 486.3708), 468 (M - H₂O), 450 (M - 2H₂O), 386 (M - H₂O - C₆H₉), 369 (M - side chain), 353 (M - side chain - H₂O), 343 (C₂₃H₃₅O₂).

Compounds 10a + 10b: TLC *R_f* = 0.37; mass spectrum (methyl ester), *m/e* 478 (M⁺), 460 (M - H₂O), 442 (M - 2H₂O), 424 (M - 3H₂O), 404 (M - C₄H₁₀O), 385 (C₂₅H₃₇O₃), 327 (M - 2H₂O - side chain), 309 (M - 3H₂O - side chain), 115 (side chain); ¹H NMR (C-D₃OD) δ 0.7 (3 H, s, C18-H), 0.9 (3 H, s, 19-H), 1.1 (3 H, s, CH₃C-(OH)CH₂CH₃).

Compounds 11a and 11b: TLC *R_f* = 0.52; mass spectrum, *m/e* 404 (M - C₄H₁₀O), 273 (M - C₄H₁₀O - H₂O - side chain), 255 (M - C₄H₁₀O - 2H₂O - side chain), 73 (C₄H₉O); ¹H NMR (CD₃OD) δ 0.7 (3 H, s, 18-H), 1.1 (3 H, s, 19-H), 1.27 (3 H, s, CH₃C(OH)CH₂CH₃).

5.2. X-ray Structure Determination. X-ray diffraction data were measured from the following complexes: (a) DCA with each of the guests, acetone, diethyl ketone, cyclohexanone, ethyl methyl ketone, and methyl pentyl ketone and (b) APA with acetone. Three-dimensional X-ray diffraction data were collected on a Siemens diffractometer by using Cu K α radiation from all the crystals at room temperature with the exception of DCA-methyl pentyl ketone. The resulting structure-factor least-squares refinements indicated that the guest molecules in

(21) Lee, D. G. In "Oxidation"; Augustine, R. L., Ed.; Marcel Dekker: New York, 1984; Vol. 1.

(22) Coppens, P.; Leiserowitz, L.; Rabinovich, D. *Acta Crystallogr.* **1965**, *18*, 1035.

Table VI. Deoxycholic Acid-Diethyl Ketone (at 293 K): x , y , and z Coordinates ($\times 10^4$ for C and O and $\times 10^3$ for H)

atom	x	y	z	atom	x	y	z
C(1)	1203 (3)	2265 (5)	3559 (14)	C(2)	654 (3)	1980 (5)	2901 (16)
C(3)	680 (3)	1290 (6)	1426 (14)	C(4)	985 (3)	1704 (6)	-276 (14)
C(5)	1530 (3)	2035 (5)	346 (15)	C(6)	1835 (3)	2411 (6)	-1334 (16)
C(7)	1641 (3)	3452 (6)	-1882 (15)	C(8)	1622 (3)	4152 (6)	-287 (3)
C(9)	1311 (3)	3742 (4)	1331 (16)	C(10)	1531 (3)	2713 (5)	1961 (13)
C(11)	1244 (3)	4491 (5)	2877 (13)	C(12)	1009 (3)	5499 (5)	2263 (11)
C(13)	1330 (3)	5934 (5)	615 (12)	C(14)	1375 (3)	5164 (5)	-860 (12)
C(15)	1619 (4)	5711 (6)	-2493 (14)	C(16)	1377 (4)	6739 (6)	-2311 (16)
C(17)	1088 (3)	6786 (5)	-476 (13)	C(18)	18857 (3)	6256 (6)	1470 (16)
C(19)	2075 (3)	2825 (6)	2820 (19)	C(20)	1087 (3)	7849 (5)	285 (14)
C(21)	824 (4)	7916 (6)	2152 (15)	C(22)	865 (3)	8581 (6)	-1036 (16)
C(23)	303 (4)	8430 (7)	-1713 (19)	C(24)	98 (4)	9211 (6)	-2845 (15)
O(25)	153 (2)	1039 (5)	821 (11)	O(26)	482 (2)	5314 (4)	1614 (9)
C(27)	83 (4)	10098 (5)	-2482 (15)	O(28)	-62 (2)	8950 (4)	-4460 (11)
H(1)	117	276	457	H(1')	138	166	404
H(2)	46	257	244	H(2')	45	167	392
H(3)	86	68	190	H(4)	80	228	-81
H(4')	102	118	-124	H(5)	171	143	79
H(6)	178	195	-239	H(6')	221	244	-102
H(7)	128	334	-240	H(7')	188	374	-283
H(8)	199	426	13	H(9)	96	362	85
H(11)	159	461	343	H(11')	101	419	383
H(12)	100	597	332	H(14)	101	500	-123
H(15)	152	540	-369	H(15')	200	574	-238
H(16)	113	686	-335	H(16')	165	725	-234
H(17)	72	662	-67	H(18)	207	564	186
H(18')	189	661	261	H(18'')	214	648	54
H(19)	229	312	205	H(19')	213	340	379
H(19'')	228	229	315	H(20)	146	804	47
H(21)	91	738	305	H(21')	44	783	216
H(21'')	93	853	294	H(22)	110	858	-214
H(22')	88	924	-41	H(23)	7	837	-63
H(23')	28	781	-247	H(25)	9	75	-30
H(26)	23	555	255	H(28)	-16	910	-593
Diethyl Ketone [$\sigma(x)$, $\sigma(y)$, $\sigma(z)$] = 2, 3, 6 ($\times 10^4$), Respectively]							
C(1)	2521	-21	2221	C(2)	2599	-48	104
C(3)	3114	448	-395	C(4)	2042	-496	3074
C(5)	2067	-358	5176	C(1)	2855	365	3178
H(1)	316	43	-177	H(2)	344	12	2
H(3)	314	116	-15	H(4)	231	30	-52
H(5)	261	-74	-33	H(6)	204	-121	277
H(7)	172	-18	257	H(8)	204	32	566
H(9)	235	-71	585	H(10)	175	-67	573

DCA-acetone and in DCA-ethyl methyl ketone could not be unambiguously located. Consequently, X-ray diffraction data of these two complexes and of DCA-methyl pentyl ketone were measured from crystals cooled to 103 K on a Nonius CAD4 diffractometer by using Mo $K\alpha$ radiation. The cell dimensions of all these crystals were determined by a least-squares procedure based on 20–25 reflections measured on the diffractometer (Table II). Details on X-ray intensity data collected from these crystals are also given in Table II.

The X-ray crystal structure refinements were carried out by using SHELX.²³ Comparison of cell constants and intensity diffraction data indicated that the DCA host structure of the complexes with acetone, diethyl ketone, ethyl methyl ketone, and methyl pentyl ketone are isomorphous, belonging to the α -packing motif (see section 2). The cell constants and diffraction data of DCA-cyclohexanone indicated that its host arrangement is isomorphous with that of DCA-di-*tert*-butyldiperoxymonocarbonate, a crystal structure we had already solved¹² and which belongs to the γ motif (see section 2). Thus, initial structure-factor least-squares refinement, involving the host atoms of DCA only were straightforward.

The C and O atoms of the host molecules were refined with individual anisotropic temperature factors. The H atoms of the host molecules whose positions were fixed by virtue of molecular structure (i.e., CH and CH₂) were inserted into their chemically reasonable positions. The methyl and hydroxyl H atoms were located by $\Delta\rho(x,y,z)$ syntheses. The x,y,z and U (isotropic) parameters of the H atoms were allowed to vary in the refinement of the low-temperature structures but were generally kept fixed in the final stages of refinement of the room-temperature structures.

The function minimized was $w(F_o - F_c)^2$ in which F_o and F_c are the observed and calculated structure factors and the weight $w = 1/\sigma^2(F_o)$, where $\sigma(F_o)$ was derived from counting statistics and the match between measured symmetry-related reflections. Each structure was refined in two blocks, full matrix not being feasible. The reliability factors given are $R(F) = \sum |F_o - F_c| / \sum F_o$, and $R_w(F) = w^{1/2} \sum |F_o - F_c| / \sum w^{1/2} F_o$. The scattering factors for H, C, and O were taken from ref 24.

5.3. DCA-Acetone. Incorrect Guest Structure of DCA-Acetone (at 293 K). Anisotropic refinement of the host molecule of the room-temperature structure yielded $R = 0.13$. The resulting electron density difference map yielded a peak distribution in the channel coplanar to within 0.2 Å and coincident with the channel axis. One acetone molecule, with a geometry taken from acetone-solvated complexes, was fitted to this peak distribution. The only way of fitting these acetone molecules as closely as possible along the channel axis was by translation of 7.2 Å. This meant that every alternate guest crystallographic site along the channel axis was vacant, resulting in a maximum occupancy of 0.5 for acetone. Refinement yielded high-temperature factors (av 0.19 Å²) for the guest atoms, which suggested that the acetone arrangement might be incorrect. Moreover, it was difficult to establish, from the diffraction data, which of the three peripheral atoms C2, C3, and O1 was oxygen. Thus, in order to better locate the guest atoms, X-ray diffraction data of DCA-acetone were measured from a crystal cooled to 103 K.

Structure Determination of DCA-Acetone (at 103 K). Anisotropic least-squares refinement of the host molecule DCA with low-temperature X-ray diffraction data gave $R = 0.12$. The resulting electron density difference map yielded eight strong peaks with heights ranging from 0.9 to 1.5 e/Å³. The number of peaks and their heights indicated that more than one guest molecule per asymmetric unit existed in the channel. We fitted two guest acetone molecules G1 and G2 to these peak positions. At this stage, we adopted the following refinement procedure. The temperature factors of G1 and G2 were fixed at 0.05 Å². This value is

(23) Sheldrick, G. M. "SHELX: Program for Crystal Structure Determination": University of Cambridge: England, 1976.

Table VII. Deoxycholic Acid–Cyclohexanone (at 293 K): *x*, *y*, and *z* Coordinates ($\times 10^4$ for Atoms C and O and $\times 10^3$ for H) of the Independent Deoxycholic Acid Molecules *A* and *B* and the Guest Cyclohexanone

atom	<i>x</i>	<i>y</i>	<i>z</i>	atom	<i>x</i>	<i>y</i>	<i>z</i>
Deoxycholic Acid, Molecule <i>A</i>							
C(1)	3817 (2)	3 274 (4)	-5640 (4)	C(2)	4300 (2)	2 979 (4)	-5212 (4)
C(3)	4216 (2)	2 256 (4)	-4405 (4)	C(4)	3866 (2)	2 697 (4)	-3680 (4)
C(5)	3374 (2)	3 005 (4)	-4127 (4)	C(6)	3019 (2)	3 443 (4)	-3355 (4)
C(7)	3185 (2)	4 477 (4)	-3012 (4)	C(18)	3276 (2)	5 224 (4)	-3821 (4)
C(9)	3635 (2)	4 761 (4)	-4565 (4)	C(10)	3445 (2)	3 747 (4)	-4954 (4)
C(11)	3769 (2)	5 532 (4)	-5318 (4)	C(12)	3985 (2)	6 505 (4)	-4911 (4)
C(13)	3632 (2)	6 977 (4)	-4174 (4)	C(14)	3512 (2)	6 178 (4)	-3438 (4)
C(15)	3237 (2)	6 762 (4)	-2675 (4)	C(16)	3512 (2)	7 781 (4)	-2665 (4)
C(17)	3849 (2)	7 812 (4)	-3535 (4)	C(18)	3169 (2)	7 358 (4)	-4690 (4)
C(19)	2949 (2)	3 869 (4)	-5493 (4)	C(20)	3892 (2)	8 895 (4)	-3928 (4)
C(21)	4186 (2)	8 965 (4)	-4861 (4)	C(22)	4103 (2)	9 616 (4)	-3191 (4)
C(23)	4641 (3)	9 412 (5)	-2885 (5)	C(24)	4843 (2)	10 219 (5)	-2265 (4)
O(25)	4696 (2)	2 044 (3)	-3995 (3)	O(26)	4456 (1)	6 283 (3)	-4483 (3)
O(27)	4694 (2)	11 057 (3)	-2223 (3)	O(28)	5211 (2)	9 916 (3)	-1734 (3)
H(1')	365	265	-587	H(1)	386	376	-614
H(2')	451	268	-570	H(2)	447	360	-494
H(4)	404	332	-344	H(3)	406	163	-468
H(5)	319	239	-441	H(4')	383	221	-318
H(6')	266	345	-358	H(6)	302	295	-279
H(7')	291	476	-258	H(7)	349	442	-265
H(9)	394	464	-417	H(8)	293	537	-418
H(11')	400	521	-576	H(11)	345	569	-568
H(14)	384	592	-318	H(12)	403	700	-546
H(15')	287	688	-288	H(15)	323	644	-205
H(16')	325	835	-263	H(16)	370	781	-204
H(18)	290	763	-428	H(17)	418	768	-334
H(18'')	318	796	-511	H(18')	302	691	-518
H((19'))	265	415	-510	H(19)	291	441	-599
H(20)	355	913	-411	H(19'')	282	332	-589
H(21')	441	957	-492	H(21)	445	845	-498
H(22)	387	963	-263	H(21'')	400	887	-546
H(23)	482	923	-344	H(22')	409	1 034	-346
H(25)	479	176	-349	H(23')	460	878	-246
H(28)	532	1 040	-134	H(26)	472	661	-479
Deoxycholic Acid, Molecule <i>B</i>							
C(1)	3937 (2)	3 333 (4)	-781 (4)	C(2)	4438 (2)	3 021 (4)	-441 (4)
C(3)	4387 (2)	2 293 (4)	360 (4)	C(4)	4077 (2)	2 727 (4)	1 153 (4)
C(5)	3569 (2)	3 084 (4)	814 (4)	C(6)	3256 (2)	3 503 (4)	1 633 (4)
C(7)	3436 (2)	4 531 (4)	1 860 (4)	C(8)	3487 (2)	5 277 (4)	1 133 (4)
C(9)	3810 (2)	4 815 (4)	328 (4)	C(10)	3596 (2)	3 807 (4)	-32 (4)
C(11)	3908 (2)	5 596 (4)	-438 (4)	C(12)	4125 (2)	6 579 (4)	-76 (4)
C(13)	3802 (2)	7 041 (4)	712 (4)	C(14)	3733 (2)	6 238 (4)	1 475 (4)
C(15)	3485 (2)	6 804 (4)	2 301 (4)	C(16)	3732 (3)	7 848 (4)	2 261 (4)
C(17)	4040 (2)	7 896 (4)	1 307 (4)	C(18)	3313 (2)	7 387 (4)	269 (4)
C(19)	3074 (2)	3 937 (4)	-465 (4)	C(20)	4034 (2)	8 970 (4)	933 (4)
C(21)	4320 (3)	9 060 (4)	-13 (4)	C(22)	4239 (2)	9 726 (4)	1 638 (4)
C(23)	4764 (3)	9 553 (5)	1 969 (5)	C(24)	4934 (2)	10 364 (5)	2 644 (5)
O(25)	4871 (2)	2 048 (3)	673 (3)	O(26)	4618 (1)	6 389 (3)	265 (3)
O(27)	4960 (2)	11 238 (3)	2 445 (3)	O(28)	5031 (2)	10 056 (3)	3 505 (3)
H(1)	397	386	-125	H(1')	375	275	-102
H(2)	462	361	-16	H(2')	462	271	-95
H(3)	424	163	13	H(4)	426	328	146
H(4')	402	217	166	H(5)	339	246	63
H(6)	323	309	219	H(6')	290	366	138
H(7)	377	442	226	H(7')	320	481	244
H(8)	315	541	88	H(9)	414	461	63
H(11)	358	573	-74	H(11')	413	527	-91
H(12)	416	701	-60	H(14)	406	606	170
H(15)	356	646	289	H(15')	311	681	218
H(16)	391	796	281	H(16')	343	835	222
H(17)	439	774	142	H(18)	306	683	14
H(18')	306	782	61	H(18'')	334	782	-30
H(18)	289	335	-75	H(19')	304	434	-105
H(19'')	280	409	-2	H(20)	368	915	77
H(21)	419	950	-53	H(21')	465	935	2
H(21'')	432	843	-41	H(22)	401	973	223
H(22')	425	1 041	138	H(23)	405	943	146
H(23')	471	887	237	H(25)	484	175	131
H(26)	484	680	-1	H(28)	518	1 063	388
Guest Cyclohexanone							
C(1)	2752 (9)	237 (18)	-2779 (20)	C(2)	2999 (8)	539 (16)	-3704 (18)
C(3)	2649 (8)	414 (14)	-4469 (13)	C(4)	2263 (7)	-327 (12)	-4518 (11)
C(5)	2032 (6)	-526 (13)	-3449 (14)	C(6)	2361 (6)	-560 (12)	-2474 (11)

Table VII (Continued)

atom	x	y	z	atom	x	y	z
O(1)	2871 (8)	592 (17)	-2054 (17)				
H(2)	310	126	-368	H(2')	329	11	-383
H(3)	247	107	-452	H(3')	286	30	-505
H(4)	201	-6	-497	H(4')	242	-94	-479
H(5)	178	1	-334	H(5')	186	-119	-348
H(6)	217	-34	-190	H(6')	252	-123	-235

Table VIII. Deoxycholic Acid-Ethyl Methyl Ketone (at 103 K): (a) x , y , and z Coordinates ($\times 10^4$) and U_{eq} (\AA^2 , $\times 10^3$) of the C and O Atom of Deoxycholic Acid (The Average $\sigma(U_{eq}) = 0.003 \text{\AA}^2$), (b) x , y , and z Coordinates ($\times 10^4$) and Isotropic U (\AA^2 , $\times 10^3$) of H Atoms of Deoxycholic Acid (Average $\sigma(x)$, $\sigma(y)$, $\sigma(z)$, and $\sigma(U)$ are 0.002, 0.004, 0.009, and 0.01\AA^2), (c) x , y , and z Coordinates^b of the Guest Ethyl Methyl Ketone Molecules G and G' (The Isotropic U Values of Each Guest Atom is $0.077 (3) \text{\AA}^2$)

(a) x , y , z , and U_{eq} of C and O Atoms of Deoxycholic Acid									
atom	x	y	z	U_{eq}	atom	x	y	z	U_{eq}
C(1)	1220 (2)	2186 (5)	3548 (9)	21	C(15)	1637 (3)	5672 (4)	-2484 (9)	26
C(2)	662 (2)	1921 (5)	2942 (9)	22	C(16)	1382 (2)	6708 (4)	-2354 (9)	20
C(3)	684 (2)	1207 (4)	1334 (9)	21	C(17)	1084 (2)	6747 (4)	-443 (8)	16
C(4)	996 (2)	1639 (4)	-281 (8)	18	C(18)	1875 (2)	6208 (4)	1460 (10)	21
C(5)	1554 (2)	1941 (4)	299 (9)	19	C(19)	2119 (2)	2767 (5)	2765 (10)	24
C(6)	1862 (2)	2368 (4)	-1343 (10)	21	C(20)	1077 (2)	7795 (4)	369 (9)	18
C(7)	1655 (2)	3396 (4)	-1911 (9)	20	C(21)	798 (3)	7874 (5)	2226 (9)	27
C(8)	1643 (2)	4112 (4)	-277 (9)	18	C(22)	864 (2)	8573 (4)	-1051 (9)	21
C(9)	1332 (2)	3671 (4)	1359 (8)	12	C(23)	284 (2)	8358 (5)	-1619 (9)	24
C(10)	1557 (2)	2656 (4)	2007 (9)	17	C(24)	86 (2)	9183 (4)	-2897 (9)	21
C(11)	1260 (2)	4427 (4)	2921 (9)	18	O(25)	163 (2)	976 (3)	807 (6)	29
C(12)	1010 (2)	5417 (4)	2285 (8)	16	O(26)	490 (1)	5222 (3)	1654 (6)	19
C(13)	1337 (2)	5895 (4)	682 (8)	13	O(27)	84 (2)	10058 (3)	-2501 (7)	38
C(14)	1396 (2)	5090 (4)	-863 (8)	13	O(28)	-76 (2)	8851 (3)	-4494 (6)	26

(b) x , y , z , and U of H Atoms of Deoxycholic Acid					(c) x , y , z , and U of Guest Molecules				
atom	x	y	z	U^a	atom	x	y	z	U^a
H(1)	1243	2554	4726	74	Molecule G [$\sigma(x)$, $\sigma(y)$, $\sigma(z) = 10, 24, 37 (\times 10^4)$, Respectively]				
H(1')	1382	1757	4017	74	O(1)	2686	282	3656	
H(2)	497	2426	2137	25	C(1)	1972	-486	5126	
H(2')	511	1623	4069	25	H(1)	2135	-187	6071	
H(3)	893	603	1527	12	H(2)	1622	-425	4892	
H(4)	1111	1101	-1109	37	H(3)	1925	-1178	5128	
H(4')	802	2143	-933	37	C(2)	2296	-207	3458	
H(5)	1722	1308	646	102	C(3)	2101	-520	1603	
H(6)	1770	2040	-2518	48	H(4)	1757	-158	1445	
H(6')	2241	2440	-1138	48	H(5)	2078	-1238	1690	
H(7)	1865	3549	-3030	25	C(4)	2454	-278	-15	
H(7')	1258	3308	-2305	25	H(6)	2802	-555	182	
H(8)	1996	4193	2	25	H(7)	2553	480	-58	
H(9)	987	3545	905	25	H(8)	2322	-535	-1236	
H(11)	1581	4705	3696	25	Molecule G' [$\sigma(x)$, $\sigma(y)$, $\sigma(z) = 11, 26, 32 (\times 10^4)$, Respectively]				
H(11')	988	4067	3756	25	O(1)	2246	-330	-320	
H(12)	1026	5971	3465	25	C(1)	2995	604	-1045	
H(14)	1030	4945	-1070	25	H(1)	2857	480	-2166	
H(15)	2145	5444	-2407	77	H(2)	3090	1220	-649	
H(15')	1605	5380	-3843	77	H(3)	3335	388	-754	
H(16)	1726	7369	-2515	30	C(2)	2615	120	276	
H(16')	1163	6850	-3493	30	C(3)	2707	265	2298	
H(17)	725	6524	-697	22	H(4)	2665	1002	2501	
H(18)	2088	6616	443	51	H(5)	3056	-1	2504	
H(18')	2098	5783	2042	51	C(4)	2338	-282	3571	
H(18'')	1803	6582	2766	51	H(6)	2341	-988	3295	
H(19)	2410	2970	1952	16	H(7)	1942	-129	3265	
H(19')	2167	2098	3283	16	H(8)	2423	-201	4923	
H(19'')	2112	3225	3643	16					
H(20)	1451	7906	622	25					
H(21)	1033	7541	3111	22					
H(21')	445	7638	1988	22					
H(21'')	657	8479	2800	22					
H(22)	930	9224	-485	20					
H(22')	1136	8359	-2063	20					
H(23)	50	8357	-393	7					
H(23')	331	7661	-2190	7					
H(25)	164	692	-421	34					
H(26)	143	5301	2256	72					
H(28)	-98	9489	-5121	40					

^aThe H atoms of each CH_2 or CH_3 group were assigned the same U value. The H atoms H(2), H(2'), H(7), H(7')...H(14) were each assigned the same U value of 0.025\AA^2 . ^bThe guest molecules G and G' were each refined as a rigid body; thus, all atoms of each molecule have the same $\sigma(x)$, $\sigma(y)$, and $\sigma(z)$.

Table IX. Deoxycholic Acid–Methyl Pentyl Ketone (at 103 K): (a) x , y , and z Coordinates ($\times 10^4$) and U_{eq} ($\text{\AA}^2, \times 10^3$) of the C and O Atoms of Deoxycholic Acid (Average $\sigma(U_{eq}) = 0.002 \text{\AA}^2$), (b) x , y , and z Coordinates ($\times 10^4$) and Isotropic U ($\text{\AA}^2, \times 10^3$) of H Atoms of Deoxycholic Acid (Average $\sigma(x)$, $\sigma(y)$, $\sigma(z)$, and $\sigma(U)$ are 0.0015, 0.0025, 0.005, and 0.01\AA^2 , Respectively), (c) x , y , and z Coordinates^b of the Guest Methyl Pentyl Ketone Molecules G and G' (The Isotropic U of Each Guest Atom = $0.057(2) \text{\AA}^2$)

(a) x , y , z , and U_{eq} and C and O Atoms of Deoxycholic Acid									
atom	x	y	z	U_{eq}	atom	x	y	z	U_{eq}
C(1)	1201 (1)	2274 (2)	3483 (5)	18	C(15)	1614 (2)	5726 (3)	-2585 (5)	22
C(2)	645 (1)	2013 (3)	2918 (5)	18	C(16)	1375 (2)	6775 (3)	-2428 (5)	21
C(3)	657 (1)	1292 (3)	1311 (5)	20	C(17)	1088 (1)	6827 (2)	-531 (5)	16
C(4)	964 (1)	1720 (3)	-304 (5)	17	C(18)	1879 (1)	6281 (3)	1343 (5)	19
C(5)	1525 (1)	2003 (3)	255 (5)	19	C(19)	2094 (1)	2823 (3)	2678 (6)	23
C(6)	1826 (1)	2428 (3)	-1412 (5)	21	C(20)	1092 (1)	7887 (2)	260 (5)	16
C(7)	1637 (2)	3455 (2)	-1979 (5)	19	C(21)	827 (2)	7977 (3)	2136 (5)	21
C(8)	1631 (1)	4186 (2)	-367 (5)	16	C(22)	861 (1)	8644 (2)	-1127 (5)	18
C(9)	1321 (1)	3754 (2)	1283 (4)	13	C(23)	288 (2)	8451 (3)	-1663 (6)	27
C(10)	1535 (1)	2732 (2)	1924 (5)	16	C(24)	87 (1)	9264 (3)	-2919 (5)	22
C(11)	1264 (1)	4527 (2)	2834 (5)	16	O(25)	126 (1)	1086 (2)	790 (4)	26
C(12)	1023 (1)	5511 (2)	2190 (5)	16	O(26)	490 (1)	5340 (2)	1617 (3)	17
C(13)	1339 (1)	5964 (2)	591 (4)	14	O(27)	60 (1)	10138 (2)	-2467 (4)	37
C(14)	1381 (1)	5166 (2)	-943 (5)	15	O(28)	-59 (1)	8956 (2)	-4554 (4)	23

(b) x , y , z , and U of H Atoms of Deoxycholic Acid					(c) x , y , z , and U of Guest Molecules				
atom	x	y	z	U	atom	x	y	z	U
H(1)	1170	2701	4545	30	Molecule G [$\sigma(x)$, $\sigma(y)$, $\sigma(z) = 7, 14, 16 (\times 10^4)$, Respectively]				
H(1')	1382	1710	3886	44	O(1)	2757	367	4284	
H(2)	454	2599	2495	5	C(1)	2049	-555	5428	
H(2')	466	1672	3937	13	H(1)	2202	-333	6461	
H(3)	857	661	1584	37	H(2)	1701	-491	5185	
H(4)	974	1312	-1351	32	H(3)	2014	-1240	5217	
H(4')	759	2239	-922	7	C(2)	2378	-118	3906	
H(5)	1707	1395	633	29	C(3)	2199	-275	1974	
H(6)	1788	1959	-2456	30	H(4)	1852	79	1896	
H(6')	2202	2542	-1230	24	H(5)	2188	-992	1839	
H(7)	1902	3714	-3040	21	C(4)	2557	121	491	
H(7')	1274	3394	-2411	16	H(6)	2907	-151	633	
H(8)	1983	4323	32	0	H(7)	2645	878	687	
H(9)	987	3662	839	16	C(5)	2380	-105	-1408	
H(11)	1601	4633	3303	20	H(8)	2356	-908	-1632	
H(11')	1023	4269	3805	15	H(9)	2052	183	-1652	
H(12)	1021	6026	3223	18	C(6)	2730	306	-2933	
H(14)	1053	5031	-1339	13	H(10)	3083	-3	-2755	
H(15)	1991	5733	-2449	31	H(11)	2679	1019	-3068	
H(15')	1529	5380	-3759	23	C(7)	2561	-3	-4788	
H(16)	1650	7308	-2530	24	H(12)	2595	-812	-4886	
H(16')	1134	6890	-3444	19	H(13)	2205	136	-5153	
H(17)	732	6639	-699	16	H(14)	2814	265	-5732	
H(18)	2074	6711	455	31	Molecule G' [$\sigma(x)$, $\sigma(y)$, $\sigma(z) = 7, 15, 16 (\times 10^4)$, Respectively]				
H(18')	2102	5745	1839	16	O(1)	2360	-429	365	
H(18'')	1844	6694	2535	19	C(1)	3096	481	-578	
H(19)	2389	3082	1855	53	H(1)	2957	287	-1654	
H(19')	2206	2156	3042	16	H(2)	3186	1120	-317	
H(19'')	2116	3263	3724	21	H(3)	3438	294	-260	
H(20)	1451	8110	451	11	C(2)	2726	66	845	
H(21)	1043	7644	3069	31	C(3)	2822	333	2809	
H(21')	492	7616	2053	26	H(4)	2774	1077	2860	
H(21'')	773	8624	2456	21	H(5)	3173	92	3054	
H(22)	892	9267	-526	4	C(4)	2463	-147	4197	
H(22')	1064	8607	-2212	29	H(6)	2471	-866	4069	
H(23)	94	8516	-459	53	H(7)	2066	-27	3879	
H(23')	265	7833	-2181	34	C(5)	2593	93	6138	
H(25)	122	793	-423	44	H(8)	2988	-158	6486	
H(26)	270	5594	2588	50	H(9)	2565	778	6364	
H(28)	-191	9535	-5179	69	C(6)	2228	-370	7566	
					H(10)	2254	-1106	7408	
					H(11)	1895	-17	7597	
					C(7)	2395	-175	9476	
					H(12)	2776	-530	9694	
					H(13)	2449	508	9847	
					H(14)	2150	-519	10354	

^b The guest molecules G and G' were each refined as a rigid body; thus, all atoms of each molecule have the same $\sigma(x)$, $\sigma(y)$, $\sigma(z)$.

very close to the refined temperature factors of ethyl methyl ketone and methyl pentyl ketone in their complexes with DCA (see section 5.6 and 5.7). The acetone molecules were refined as rigid bodies, yielding $R = 0.099$, and occupancies of 0.34 (2) for G1 and 0.33 (2) for G2. We then

fixed the occupancies of G1 and G2 at $1/3$ and refined one temperature factor parameter of both G1 and G2. The resulting U value appeared to be too high at 0.09\AA^2 , suggesting that the model was still not correct, as evidenced by a difference map showing five peaks in the channel region

with heights ranging from 0.7 to 1.0 $e/\text{\AA}^3$. Four of these peaks were easily fitted to an acetone molecule. Therefore, a third acetone guest G3 was inserted and refined as a rigid group. R converged to 0.072. The resulting occupancies of the three acetone molecules were each close to 0.2 (0.24 (1) for G1, 0.18 (1) for G2, and 0.24 (1) for G3; the guest molecular thermal parameter, taken to be the same for G1 and G2 and G3, refined to 0.056 (3) \AA^2). The occupancies of G1, G2, and G3 were each set equal to 0.2 for reasons outlined in section 3.2. Refinement yielded an overall guest temperature factor of 0.053 (3) \AA^2 and R stayed put at 0.072. As a check that the oxygen and carbon atoms of each acetone molecule had been correctly located, the contributions of each of these atoms were removed one at a time from the least-squares refinement and an electron density difference map was calculated after a least-squares cycle. The resulting peak heights and their positions indicated that these atoms were correctly placed. The peak heights of the oxygen atoms of G1, G2, and G3 were 1.1, 1.1, and 1.2 $e/\text{\AA}^3$, respectively; those of the carbon atoms ranged from 0.7 to 0.9 $e/\text{\AA}^3$.

Refinement of DCA-Acetone (at 293 K). We used the final x, y, z coordinates of the low-temperature structure of DCA-acetone as a starting model for refinement of the structure at 293 K, which yielded an R value of 0.086. The final isotropic U value for the guest atoms was 0.113 (6) \AA^2 , keeping the occupancies of molecules G1, G2, and G3 each fixed at 0.2.

5.4. APA-Acetone (at 293 K). The crystal structure was determined via MULTAN.²⁵ The C' and O' atoms of the guest acetone were unambiguously located because the plane of the acetone moiety $>C=O'$ is perpendicular to the channel axis so that there is no molecular overlap between symmetry-related guest sites along the channel. The host-guest molar ratio is 1:1. On refinement R converged to 0.083.

5.5. DCA-Diethyl Ketone (at 293 K). The host atoms were refined anisotropically to an R value of 0.15. A difference map yielded a set of peaks in the channel coplanar to within 0.25 \AA . The two atomic peaks corresponding to the guest $C'=O'$ system were clearly evident. The remaining four C atoms of the molecule were easily assigned to the peak distribution. These peaks were interpreted in terms of one guest molecule per asymmetric unit. The guest molecule G is so oriented in the channel that only every alternate crystallographic site in the channel may be occupied, namely G sites related by c translation [i.e., $G(x, y, z)$, $G(x, y, 1 + z)$, $G(x, y, 2 + z)$], as shown in Figure 8A. Adjacent guest sites related by twofold screw symmetry, i.e., $G(x, y, z)$, $G(1/2 - x, -y, 1/2 + z)$, are precluded because that would lead to interpenetration between neighboring guest molecules. Thus, the maximum occupancy of the guest molecule equals 0.5. On refinement this occupancy value was assigned to diethyl ketone which was treated as a rigid body. A final R value of 0.11 was obtained, and the average isotropic U value of diethyl ketone converged to 0.15 \AA^2 .

5.6. DCA-Methyl Pentyl Ketone (at 103 K). Refinement of the host structure yielded an $R = 0.13$. The resulting electron density difference map displayed seven independent distinct peaks within the channel, coplanar to within 0.2 \AA , with heights ranging from 1.0 to 2.3 $e/\text{\AA}^3$ as shown in Figure 12. These peaks are arranged in a pseudocentrosymmetric pattern, indicating an even number of coplanar guest molecules per asymmetric unit. These peaks were interpreted in terms of two independent guest molecules G and G', forming a pseudocentrosymmetric dimer.

A molecular model of the guest²⁶ was fitted to the peak positions and was constrained as a rigid group with the same temperature parameter for both G and G' during the refinement. The occupancy factors of the two guests G and G' were refined separately to values of 0.174 (5) and 0.159 (5). An overall thermal parameter of 0.057 (2) \AA^2 for G and G' was obtained. The total occupancy was 0.333 (7), almost equal to 1:3.

We now digress to demonstrate in terms of guest packing in the channel that the maximum total occupancy is 1:3 and that the occupancies of G and G' should be exactly the same. For this analysis, we shall naturally assume the derived crystallographic locations of G and G'.

We first pose the question whether G and G' each pack in separate strings GGGGG and G'G'G'G'G' along a channel. In each such a string, nearest-neighboring guests would occupy every third consecutive crystallographic site in the channel, as shown in Figure 13 for G' molecules. Were G and G' to form such separate strings, the maximum total guest

occupancy would be 1:3, the observed value. In this arrangement, there appears to be no constraint for the occupancies of G and G' to be almost equal to each other, as was actually found. The alternative arrangement within a channel is shown in Figure 11, containing nicely packed GG' dimers 13 juxtaposed along the channel by a translation repeat of 3c so the maximum guest occupancy is 1:3, and the molar ratio of G to G' is 1:1. This latter value is only two esd's removed from the X-ray derived molar ratio of 1.09 (5). The discrepancy of 0.09 may be accounted for in terms of the pronounced molecular overlap between G and G' in the

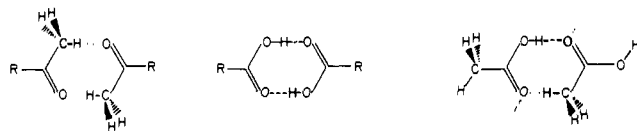

refinement and hence a high correlation between the molecular occupancies of G and G'. Assuming the guest arrangement in Figure 11, as against Figure 13, obviates the need to explain why G and G' are differently oriented and offset with respect to each other. The proposed arrangement of acetyl groups in dimer form 13 actually occurs in crystal structures of 4-acetylbiphenyl derivatives.²⁷ Motif 13 is analogous to the H-bonded carboxylic acid dimer 14 and the "dimer" 15 found in the crystal structures of acetic acid²⁸ and the complex DCA-acetic acid.¹¹ Dimer 13 and 15 has been interpreted in terms of an attractive C-H...O Coulomb interaction.²⁹ Thus, we conclude that G and G' appear in dimer form 13. On this basis we assumed that the individual occupancies of G and G' are each 1:6 in the final cycles of refinement. The overall thermal parameter of the guest remained unchanged as well as the final R and R_w values of 0.058 and 0.056, respectively.

For our molecular model of methyl pentyl ketone, we had taken the $C=O$ and $C_\alpha-C_\beta$ bonds of $O=C-C_\alpha-C_\beta$ to be cis to each other, which is consistent with the relative atomic peak heights from difference Fourier maps and from crystal structures which contain methyl alkyl ketone moieties.^{26,30} Moreover, similar conformations exist in the solid for the analogous molecular systems of the α, β saturated carboxylic acids and esters, primary and secondary amides, *N*-methylacetamide, and the peptide linkage, as depicted in Scheme VII.

Nevertheless, we carried out the following least-squares analysis to verify the inserted cis conformation. The moieties $C(CH_2)_4CH_3$ of the methyl pentyl ketone guests G and G' were each refined as rigid bodies. The two remaining atoms O1 and C1 of each guest were refined freely but for a restraint in distance of 2.34 \AA between O1 and C1. The refined geometries (in angstroms, Scheme VIII) confirm unequivocally that $O=C-C_\alpha-C_\beta$ is cis. This refinement yielded $R = 0.060$ and $R_w = 0.059$.

5.7. DCA-Ethyl Methyl Ketone. Structure Determination at 103 K. Anisotropic refinement of DCA with the low-temperature (103 K) X-ray diffraction data yielded an $R = 0.13$. An electron-density difference synthesis exhibited several peaks in the channel with heights ranging from 1.0 to 2.2 $e/\text{\AA}^3$. The peaks were coplanar in an almost centrosymmetric pattern (Figure 14). This peak distribution was interpreted in terms of two independent guest molecules G and G', forming a pseudocentrosymmetric pair. The ketone oxygen atoms were located from peak height (i.e., the highest of the seven peaks) and peak-peak distances. The molecular model of ethyl methyl ketone was derived from the crystal structure of 9-keto-*trans*-2-decenoic acid.²⁶ G and G' were refined as rigid groups and were assigned the same temperature factor. The refined occupancy factors of ethyl methyl ketone molecules were 0.23 (2) for G' and 0.25 (2) for G. When G and G' were refined with the same occupancy factor, 0.241 (3) was obtained. Following arguments parallel to those outlined above for methyl pentyl ketone, we may conclude that G and G' form a string of centrosymmetric dimers which are related to each other by a translation axis of $2c$ in the channel as shown in Figure 9. In this packing motif, the occupancies of the G and G' molecules are each 0.25, which fits very close to the refined value of 0.24. The intermolecular distances between guest molecules G and G' both for intra- and interdimer contacts are most reasonable, i.e., 3.4 \AA between C1(G) and

(24) (a) Stewart, R. F.; Davidson, E. R.; Simpson, W. T. *J. Chem. Phys.* **1965**, *42*, 3175. (b) Cromer, D. T.; Mann, J. B. *Acta Crystallogr., Sect. A* **1968**, *A24*, 321.

(25) Germain, G.; Main, P.; Woolfson, M. M. *Acta Crystallogr., Sect. A* **1971**, *A27*, 368.

(26) Model derived from the crystal structure of 9-keto-*trans*-2-decenoic acid: Cromer, D. T.; Larson, A. C. *Acta Crystallogr., Sect. B* **1972**, *B28*, 2128.

(27) Sutherland, H. H.; Hoy, T. G. *Acta Crystallogr., Sect. B* **1968**, *B24*, 1207. Sutherland, H. H.; Hoy, T. G. *Ibid.* **1969**, *B25*, 2385.

(28) Nahringsbauer, I. *Acta Chem. Scand.* **1970**, *24*, 453.

(29) Berkovitch-Yellin, Z.; Leiserowitz, L. *Acta Crystallogr., Sect. B* **1984**, *B40*, 159.

(30) King, T. J.; Rodrigo, S.; Wallwork, S. C. *J. Chem. Soc. D* **1969**, 683. Charles, C.; Braeckman, J. C.; Daloze, D.; Tursch, B.; Declercq, J. P.; Germain, G.; van Meerse, M. *Bull. Soc. Chim. Belg.* **1978**, *87*, 481. Dideberg, O.; Dupont, L.; Christoffidis, I. *Cryst. Struct. Commun.* **1976**, *5*, 377; Grigorjeva, N. V.; Margolis, N. V.; Shokhor, I. N.; and Tselinskii, I. V. *Zh. Strukt. Khim.* **1969**, *10*, 559.

O1(G'), 3.8 Å between O1(G) and C1(G'), and 4.6 Å across the gap C4(G')...C4(G). Therefore, the occupancies of G and G' were kept fixed at 0.25, yielding $R = 0.099$, $R_w = 0.097$, and an isotropic U value of 0.077 (3) Å² for the guest atoms.

We had assumed for G and G' a cis C_β-C_α-C=O conformation as had been definitely indicated by the difference map in which the oxygen peaks were by far the highest (Figure 14) and by the evidence already provided above in the analysis on DCA-methyl pentyl ketone. Moreover, the acetyl moieties of the ethyl methyl ketone G and G' molecules occupy almost the same locations (relative to steroid host) in the channel as the corresponding H₃CCOC₂H₄ moieties of methyl pentyl ketone. Nevertheless, least-squares calculations were carried out to verify the positions of atoms O1 and C1 of ethyl methyl ketone in a procedure akin to that adopted on methyl pentyl ketone. The refinement yielded $R = 0.095$ and $R_w = 0.094$. The refined geometries of the guests, shown in Scheme IX (in angstroms) did not distinguish between the oxygen and methyl groups certainly not in terms of the esd's in the C=O and C-CH₃ bond lengths. Nevertheless, in terms of all the facts presented here, there can be no doubt as to the cis conformation of C_β-C_α-C=O in ethyl methyl ketone.

Structure Determination (at 293 K). The final x , y , and z coordinates of DCA-ethyl methyl ketone at 103 K were used as a starting model for refinement of the room-temperature crystal structure. An R value of 0.097 was obtained. The isotropic thermal parameter of the guest molecules converged to 0.169 (6) Å², keeping the occupancies of G and G' each fixed at 0.25.

5.8. DCA-Cyclohexanone (at 293 K). The crystal structure was solved by MULTAN²⁵ although we had strong reason to believe that the host structure was isomorphous with that of DCA-di-*tert*-butyl diperoxymonocarbonate,¹² as indeed it proved to be. The host structure belongs to the γ motif. The C and O atoms of the guest molecule were unambiguously located, not being subject to disorder by virtue of the 14-Å c axis. The occupancy of the guest molecule was taken to be 0.5, its maximum possible value. Refinement proceeded smoothly to an R

value of 0.086; the average U value of the guest C and O atoms was 0.23 Å².

5.9. Results of X-ray Crystal Structure Refinements. Details on the final cycle of refinements are given in Table III. The atomic x , y , and z coordinates and U_{eq} of DCA-acetone (at 103 K), APA-acetone, DCA-diethyl ketone, DCA-cyclohexanone, DCA-ethyl methyl ketone (at 103 K), and DCA-methyl pentyl ketone are listed in Tables IV-IX, respectively. Anisotropic temperature factors U_{ij} , bond lengths, and bond angles are listed in supplementary material Tables 4S-9S; the x , y , and z coordinates of DCA-acetone (at 293 K) and DCA-ethyl methyl ketone (at 293 K) are listed in Tables 4S and 8S, respectively.

Acknowledgment. We thank Prof. M. D. Cohen for fruitful discussions. We thank the Israel/U.S. Binational Science Foundation and the Israel Academy of Science and Humanities for financial support.

Registry No. 1, 66014-00-4; **1** (methyl ester), 95484-83-6; **2**, 66014-23-1; **2** (methyl ester), 95484-84-7; **3**, 66971-13-9; **3** (methyl ester), 95615-84-2; **4**, 66014-20-8; **5**, 95484-85-8; **6**, 83035-68-1; **6** (methyl ester), 95484-86-9; **7**, 58678-36-7; **7** (methyl ester), 95484-87-0; **8**, 77522-07-7; **9**, 95484-88-1; **9** (methyl ester), 95484-89-2; **10** (isomer 1), 95586-12-2; **10** (methyl ester) (isomer 1), 95484-90-5; **10** (isomer 2), 95586-13-3; **10** (methyl ester) (isomer 2), 95484-91-6; **11** (isomer 1), 95586-14-4; **11** (isomer 2), 95586-15-5; DCA-³/₅acetone, 83035-57-8; DCA-¹/₂(diethyl ketone), 83047-97-6; DCA-¹/₂cyclohexanone, 95484-92-7; DCA-¹/₂(ethyl methyl ketone), 83035-64-7; DCA-¹/₃(methyl pentyl ketone), 95484-93-8; APA-acetone, 66971-12-8.

Supplementary Material Available: Thermal parameters, bond angles, and bond lengths of molecules A and B (26 pages). Ordering information is given on any masthead page.

Reaction Pathways in Crystalline Host-Guest Inclusion Complexes: Rotation by a Net 180° of the Acetyl Group on Photoaddition of Guest-Acetophenone and -*m*-Chloroacetophenone to the Atom C5 of Host Deoxycholic Acid

C. P. Tang,^{1a} H. C. Chang,^{1a} R. Popovitz-Biro,^{1a} F. Frolow,^{1a} M. Lahav,^{*1a} L. Leiserowitz,^{*1a} and R. K. McMullan^{1b}

Contribution from the Department of Structural Chemistry, The Weizmann Institute of Science, Rehovot, Israel 76100, and the Department of Chemistry, Brookhaven National Laboratory, Upton, New York 11793. Received July 11, 1984

Abstract: The crystalline host-guest channel inclusion complexes 5:2 (DCA) deoxycholic acid-acetophenone (C₆H₅C(O)CH₃) and 3:1 DCA-*m*-chloroacetophenone (CLC₆H₄C(O)CH₃) each yield on UV irradiation a photoproduct via addition of guest to the steroid tertiary carbon atom C5 with the formation of a new chiral carbon center C'(OH)(CH₃)(C₆H₅)(DCA) of S configuration. The crystal structures of the two host-guest complexes were determined by low-temperature (103 K) X-ray diffraction; a low-temperature (16 K) neutron study was made on DCA-C₆H₅COCD₃. The inclusion compounds DCA-C₆H₅COCH₃ and DCA-CLC₆H₄COCH₃ each contain two crystallographically independent guest molecules G and G' arranged along the channel axes such that both G and G' should form the same diastereomeric product at C5. A comparison of the stereochemistry of each of the two isolated photoproducts and the host-guest arrangements at the reaction sites in each corresponding complex indicates that photoaddition of the guest molecule to C5 takes place with a net rotation of 180° by the guest acetyl group.

1. Introduction

1.1. Statement of the Problem. In the previous paper in this issue,² we described the regiospecific solid-state photoaddition of

several guest aliphatic ketones to the host deoxycholic acid (referred to as DCA) in the channels of the bile acids. A comparative analysis of the stereochemistries of the reaction products formed,

(1) (a) Weizmann Institute of Science. (b) Brookhaven National Laboratory.

(2) Popovitz-Biro, R.; Tang, C. P.; Chang, H. C.; Lahav, M.; Leiserowitz, L. *J. Am. Chem. Soc.*, preceding paper in this issue.